



**PASLANMAZ
GRUBU**
STAINLESS
STEELS

INOX SİLİNDİR BAŞ METRİK VİDA

SLOTTED PAN HEAD SCREWS

ZYLINDERSCHRAUBE MIT SCHLITZ

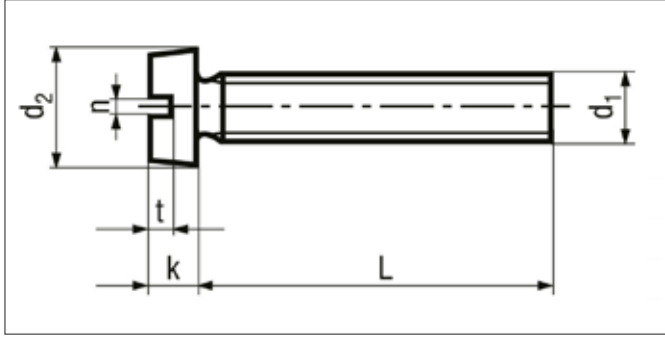

ISO	UNI	DIN
1207	6107	84 A2/A4
Mekanik Özellikler - Toleranslar Mechanical Properties - Tolerances Mechanische Eigenschaften - Toleranzen		ISO 3506-1 ISO 4759-1

TEKNİK BİLGİLER		TECHNICAL INFORMATIONS					TECHNISCHE INFORMATION			
d		M2	M2,5	M3	M4	M5	M6	M8	M10	
dk	max	3,8	4,50	5,50	7	8,5	10	13	16	
	min	3,62	4,32	5,32	6,78	8,28	9,78	12,73	15,73	
k	max	1,3	1,66	2	2,6	3,3	3,9	5	6	
	min	1,16	1,46	1,86	2,46	3,12	3,60	4,70	5,70	
n	max	0,70	0,80	1,00	1,51	1,51	1,91	2,31	2,81	
	min	0,56	0,66	0,86	1,26	1,26	1,66	2,06	2,56	
t	min	0,60	0,7	0,85	1,10	1,30	1,60	2,00	2,4	

l	min	max	M2	M2,5	M3	M4	M5	M6	M8	M10
4	3,76	4,24		0,31	0,53					
5	4,76	5,24	0,20	0,34	0,58					
6	5,76	6,24	0,22	0,37	0,62	1,20	2,11			
8	7,71	8,29	0,26	0,43	0,71	1,37	2,36	3,66		
10	9,71	10,29	0,30	0,50	0,80	1,51	2,62	4,03	8,06	
12	11,65	12,35	0,34	0,56	0,89	1,67	2,88	4,39	8,72	14,99
14	13,65	14,35	0,37	0,62	0,98	1,84	3,13	4,74	9,38	16,02
16	15,65	16,35	0,41	0,67	1,07	2,00	3,39	5,11	10,03	17,05
20	19,58	20,42	0,49	0,80	1,25	2,33	3,90	5,85	11,30	19,10
25	24,58	25,42	0,59	0,96	1,48	2,71	4,52	6,74	12,94	21,67
30	29,58	30,42			1,70	3,10	5,16	7,65	14,58	24,24
35	34,50	35,50			1,93	3,50	5,77	8,47	16,23	26,80
40	39,50	40,50			2,16	3,90	6,42	9,45	17,87	29,37
45	44,50	45,50			2,38	4,30	7,07	10,27	19,41	31,94
50	49,50	50,50			2,61	4,70	7,70	11,19	21,16	34,51
55	54,05	55,95			2,83	5,10	8,35	12,12	22,70	37,07
60	59,05	60,95			3,06	5,50	8,99	13,04	24,34	39,64
70	69,05	70,95					10,27	14,89	27,52	44,78
80	79,05	80,95					11,56	16,74	30,60	49,91

INOX GUPİLYA

SPLINT PINS

SPLINT

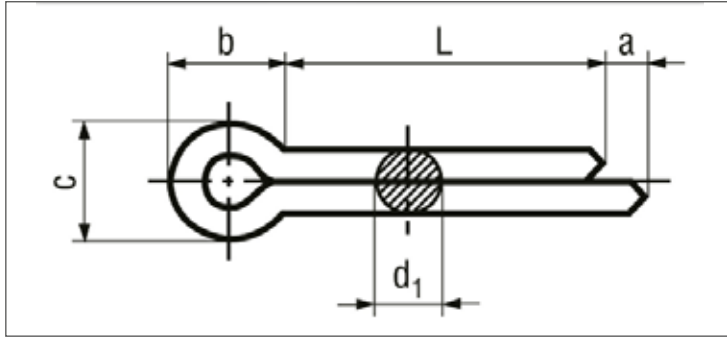

ISO	UNI	DIN
1234	1336	94 A2/A4
Mekanik Özellikler - Toleranslar Mechanical Properties - Tolerances Mechanische Eigenschaften - Toleranzen		ISO 3506-3

TEKNİK BİLGİLER		TECHNICAL INFORMATION				TECHNISCHE INFORMATION			
d	max	1,6	2	2,5	3,2	4	5	6,3	
	min	1,4	1,8	2,3	2,9	3,7	4,6	5,9	
c	max	2,8	3,6	4,6	5,8	7,4	9,2	11,8	
	min	2,4	3,2	4,0	5,1	6,5	8,0	10,3	
b	≈	3,2	4	5	6,4	8	10	12,6	
a	max	2,5	2,5	2,5	3,2	4	4	4	
	min	1,25	1,25	1,25	1,6	2	2	2	

l	min	max	1,5	2	2,5	3	4	5	6
10	9,25	10,75	0,14	0,24					
16	15,10	16,90	0,20	0,34	0,59	0,97	1,71	2,84	
20	19,00	21,00	0,26	0,44	0,75	1,23	2,13	3,50	
25	24,00	26,00	0,32	0,55	0,92	1,49	2,56	4,16	
32	30,75	33,25	0,38	0,65	1,08	1,76	2,99	4,82	8,25
36	34,75	37,25	0,44	0,75	1,25	2,02	3,41	5,48	9,33
40	38,75	41,25	0,50	0,85	1,41	2,28	3,84	6,14	10,42
45	43,75	46,25		0,95	1,58	2,54	4,27	6,80	11,51
50	48,75	51,25			1,74	2,81	4,70	7,46	12,59
63	61,50	64,50				3,33	5,55	8,78	14,76
71	69,50	72,50					6,40	10,09	16,93
80	78,50	81,50						11,41	19,10
90	88,25	91,75						12,73	21,27
100	98,25	101,75						14,05	23,44
112	110,25	113,75							
125	123,00	127,00							

INOX GÖZLÜ CIVATA

EYEBOLT

AUGENSCHRAUBEN TYP B

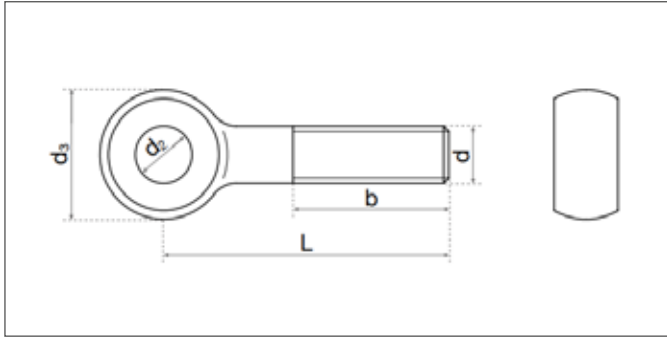

ISO	UNI	DIN
-	6058	444 B A2/A4
Mekanik Özellikler - Toleranslar Mechanical Properties - Tolerances Mechanische Eigenschaften - Toleranzen		ISO 3506-1 ISO 4759-1

TEKNIK BİLGİLER			TECHNICAL INFORMATION				TECHNISCHE INFORMATION	
d1		M6	M8	M10	M12	M16	M20	
p		1	1,25	1,5	1,75	2	2,5	
b +2 P	1)	18	22	26	30	38	46	
	2)		28	32	36	44	52	
	3)				49	57	65	
d2	H9 5)	6	8	10	12	16	18	
d3	max	14	18	20	25	32	40	
	min	Type A	12,9	16,9	18,7	23,7	30,4	38,4
		Type C and B	13,57	17,57	19,48	24,48	31,38	39,38
r	≈	4	4	4	6	6	6	
s	Type A	max	9	11	14	17	19	24
		min	8,52	10,3	13,3	16,3	18,16	23,16
	Type B and C	max	7	9	12	14	17	22
		min	6,85	8,85	11,82	13,82	16,82	21,79

l	min	max	M6	M8	M10	M12	M16	M20
40	39,20	40,80	13,70	25,00				
50	49,20	50,80	15,90	28,90	39,10			
60	59,05	60,95	18,10	32,80	45,30	71,40		
70	69,05	70,95	20,30	36,80	51,50	80,30	149,00	
80	79,05	80,95	22,60	40,70	57,60	89,20	164,00	
90	88,90	91,10	23,70	44,70	63,80	98,10	180,00	
100	98,90	101,10		48,60	70,00	106,00	196,00	334,00
110	108,90	111,10		52,60	76,10	115,00	212,00	359,00
120	118,90	121,10		56,50	82,30	124,00	228,00	383,00
130	128,75	131,25		60,50	88,40	133,00	244,00	408,00
140	138,75	141,25		64,40	94,50	142,00	259,00	433,00
150	148,75	151,25			101,00	151,00	275,00	457,00
160	158,75	161,25				160,00	291,00	482,00
180	178,75	181,25				178,00	322,00	531,00
200	198,55	201,45				195,00	354,00	581,00
220	218,55	221,45				211,00	383,00	624,00
240	238,55	241,45				229,00	414,00	674,00
260	258,40	261,60				247,00	446,00	723,00

INOX MİL EMNİYET SEGMANI TİP A

RETAINING RINGS FOR SHAFTS TYPE A

SICHERUNGSRING FÜR WELLEN TYP A

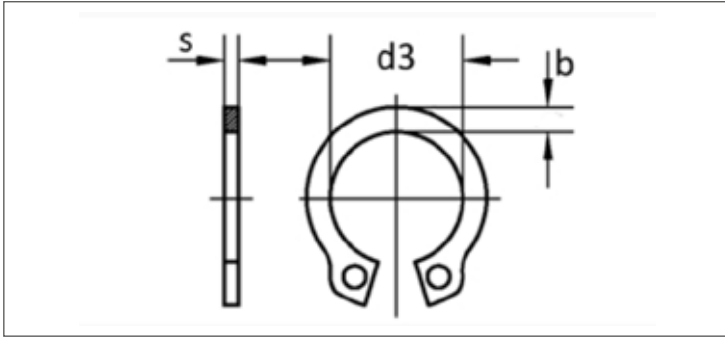

ISO	UNI	DIN
-	7435	471 A2
Mekanik Özellikler - Toleranslar Mechanical Properties - Tolerances Mechanische Eigenschaften - Toleranzen		ISO 3506-3

TEKNİK BİLGİLER TECHNICAL INFORMATION TECHNISCHE INFORMATION

d	d3	s	a max	b ≈	d5	gr
4	3,7	0,4	2,2	0,9	1,0	0,033
5	4,7	0,6	2,5	1,1	1,0	0,080
6	5,6	0,7	2,7	1,3	1,2	0,126
7	6,5	0,8	3,1	1,4	1,2	0,192
8	7,4	0,8	3,2	1,5	1,2	0,225
9	8,4	1	3	2	1	0,379
10	9,3	1	3	2	1	0,420
11	10,2	1	3	2	2	0,454
12	11,0	1	3	2	2	0,490
13	11,9	1	3	2	2	0,584
14	12,9	1	4	2	2	0,652
15	13,8	1	4	2	2	0,732
16	14,7	1	4	2	2	0,810
17	15,7	1	4	2	2	0,892
18	16,5	1,2	3,9	2,4	1,7	1,198
19	17,5	1,2	3,9	2,5	2,0	1,253
20	18,5	1,2	4,0	2,6	2,0	1,320
21	19,5	1,2	4,1	2,7	2,0	1,480
22	20,5	1,2	4,2	2,8	2,0	1,621
23	21,5	1,2	4,3	2,9	2,0	1,745
24	22,2	1,2	4,4	3,0	2,0	1,801
25	23,2	1,2	4,4	3,0	2,0	1,928
26	24,2	1,2	4,5	3,1	2,0	2,019
27	24,9	1,2	4,6	3,1	2,0	2,170
28	25,9	1,5	4,7	3,2	2,0	2,870
29	26,9	1,5	4,8	3,4	2,0	3,100
30	27,9	1,5	5,0	3,5	2,0	3,294
31	28,6	1,5	5,0	3,5	2,5	3,301
32	29,6	1,5	5,2	3,6	2,5	3,887
33	30,5	1,5	5,2	3,7	2,5	3,639
34	31,5	1,5	5,4	3,8	2,5	4,221
35	32,5	1,5	5,6	3,9	2,5	4,365
36	33,2	1,75	5,60	4,00	2,50	4,719
37	34,2	1,75	5,70	4,10	2,50	5,260
38	35,2	1,75	5,80	4,20	2,50	6,203
39	36,0	1,75	5,90	4,30	2,50	6,668
40	36,5	1,75	6,00	4,40	2,50	6,234

d	d3	s	a max	b ≈	d5	gr
41	37,5	1,75	6,2	4,5	2,5	6,440
42	38,5	1,75	6,5	4,5	2,5	6,884
43	39,5	1,75	6,5	4,5	2,5	6,884
44	40,5	1,75	6,6	4,6	2,5	7,958
45	41,5	1,75	6,7	4,7	2,5	7,573
46	42,5	1,75	7	5	3	7,650
47	43,5	1,75	7	5	3	7,840
48	44,5	1,75	7	5	3	8,160
50	45,8	2	7	5	3	10,706
52	47,8	2	7	5	3	11,328
54	49,8	2	7	5	3	12,512
55	50,8	2	7	5	3	12,413
56	51,8	2	7	6	3	11,684
57	52,8	2	7	6	3	13,464
58	53,8	2	7,3	5,6	2,5	13,119
60	55,8	2	7,4	5,8	2,5	13,866
62	57,8	2	7,5	6,0	2,5	14,266
63	58,8	2	7,6	6,2	3,0	14,540
65	60,8	2,5	7,8	6,3	3,0	21,225
67	62,5	2,5	7,9	6,4	3,0	20,520
68	63,5	2,5	8,0	6,5	3,0	22,125
70	65,5	2,5	8,1	6,6	3,0	23,349
72	67,5	2,5	8,2	6,8	3,0	23,727
75	70,5	2,5	8,4	7,0	3,0	24,549
77	72,5	2,5	8,5	7,2	3,0	25,976
78	73,5	2,5	8,6	7,3	3,0	26,366
80	74,5	2,5	8,6	7,4	3,0	27,517
82	76,5	2,5	8,7	7,6	3,0	27,993
85	79,5	3	8,7	7,8	3,5	38,109
87	81,5	3	8,8	7,9	3,5	39,904
88	82,5	3	8,8	8,0	3,5	38,088
90	84,5	3	8,8	8,2	3,5	41,504
92	86,5	3	9,00	8,40	3,50	42,548
95	89,5	3	9,40	8,60	3,50	44,660
97	91,5	3	9,40	8,80	3,50	47,924
98	92,5	3	9,40	8,80	3,50	47,924
100	94,5	3	9,60	9,00	3,50	47,035

INOX DELİK EMNİYET SEGMANI TİP J

RETAINING RINGS FOR HOLES (INTERNALS)

SICHERUNGSRING FÜR WELLEN TYP J

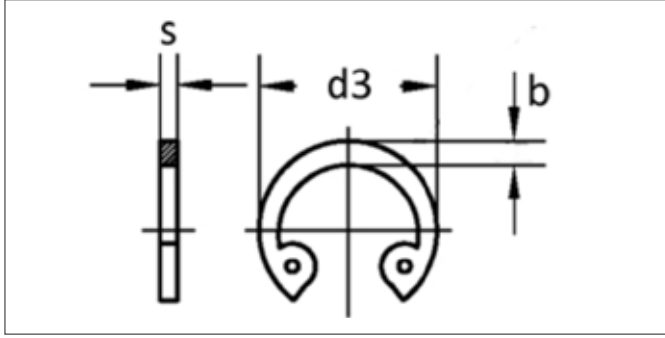

ISO	UNI	DIN
-	7437	472 A2
Mekanik Özellikler - Toleranslar Mechanical Properties - Tolerances Mechanische Eigenschaften - Toleranzen		ISO 3506-3

TEKNIK BİLGİLER TECHNICAL INFORMATIONS TECHNISCHE INFORMATION

d	d3	s	a max	b ≈	d5	gr
8	8,7	0,8	2,4	1,1	1,0	0,122
9	9,8	0,8	2,5	1,3	1,0	0,147
10	10,8	1	3,2	1,4	1,2	0,267
11	11,8	1	3,3	1,5	1,2	0,300
12	13,0	1	3,4	1,7	1,5	0,318
13	14,1	1	3,6	1,8	1,5	0,372
14	15,1	1	3,7	1,9	1,7	0,417
15	16,2	1	3,7	2,0	1,7	0,478
16	17,3	1	3,8	2,0	1,7	0,510
17	18,3	1	3,9	2,1	1,7	0,557
18	19,5	1	4,1	2,2	2,0	0,656
19	20,5	1	4,1	2,2	2,0	0,687
20	21,5	1	4,2	2,3	2,0	0,730
21	22,5	1	4,2	2,4	2,0	0,810
22	23,5	1	4,2	2,5	2,0	0,883
23	24,6	1,2	4,2	2,5	2,0	1,113
24	25,9	1,2	4,4	2,6	2,0	1,228
25	26,9	1,2	4,5	2,7	2,0	1,340
26	27,9	1,2	4,7	2,8	2,0	1,464
27	29,1	1,2	4,7	2,9	2,0	1,587
28	30,1	1,2	4,8	2,9	2,0	1,630
29	31,1	1,2	4,8	3,0	2,0	1,729
30	31,1	1,2	4,8	3,0	2,0	1,808
31	33,4	1,2	5,2	3,2	2,5	1,952
32	24,4	1,2	5,4	3,2	2,5	2,640
33	35,5	1,2	5,4	3,3	2,5	2,200
34	36,5	1,5	5,4	3,3	2,5	3,055
35	37,8	1,5	5,4	3,4	2,5	3,047
36	38,8	1,5	5,4	3,5	2,5	3,458
37	39,8	1,5	5,5	3,6	2,5	3,425
38	40,8	1,5	5,5	3,7	2,5	3,485
39	42,0	1,5	5,6	3,8	2,5	3,620
40	43,5	1,75	5,8	3,9	2,5	4,653
41	44,5	1,75	5,9	4,0	2,5	5,287
42	45,5	1,75	5,9	4,1	2,5	5,553
43	46,5	1,75	5,9	4,2	2,5	5,701

d	d3	s	a max	b ≈	d5	gr
44	47,5	1,75	6,0	4,2	2,5	5,135
45	48,5	1,75	6,2	4,3	2,5	5,777
46	49,5	1,75	6,3	4,4	2,5	6,439
47	50,5	1,75	6,4	4,4	2,5	6,517
48	51,5	1,75	6,4	4,5	2,5	6,792
50	54,2	2	6,5	4,6	2,5	8,228
51	55,2	2	6,5	4,7	2,5	9,370
52	56,2	2	6,7	4,7	2,5	8,501
53	57,2	2	6,7	4,9	2,5	9,210
54	58,2	2	6,7	5,0	2,5	9,357
55	59,2	2	6,8	5,0	2,5	9,584
56	60,2	2	6,8	5,1	2,5	9,717
57	61,2	2	6,8	5,1	2,5	9,970
58	62,2	2	6,9	5,2	2,5	10,650
60	64,2	2	7,3	5,4	2,5	10,990
62	66,2	2	7,3	5,5	2,5	11,370
63	67,2	2	7,3	5,6	2,5	12,531
65	69,2	2,5	7,6	5,8	3,0	16,40
67	71,5	2,5	7,7	6,0	3,0	17,75
68	72,5	2,5	7,8	6,1	3,0	17,90
70	74,5	2,5	7,8	6,2	3,0	19,19
72	76,5	2,5	7,8	6,4	3,0	20,085
75	79,5	2,5	7,8	6,6	3,0	21,25
77	81,5	2,5	8,5	6,8	3,0	23,90
78	82,5	2,5	8,5	6,8	3,0	23,90
80	85,5	2,5	8,5	7,0	3,0	24,87
82	87,5	2,5	8,5	7,0	3,0	25,57
85	90,5	3	8,6	7,2	3,5	31,81
87	92,5	3	8,6	7,4	3,5	34,42
88	93,5	3	8,6	7,4	3,5	34,42
90	95,5	3	8,6	7,6	3,5	36,19
92	97,5	3	8,7	7,8	3,5	36,51
95	100,5	3	8,8	8,1	3,5	39,26
97	100,5	3	9,0	8,3	3,5	40,00
98	102,5	3	9,0	8,3	3,5	40,00
100	105,5	3	9,2	8,4	3,5	42,11

INOX ALTİKÖŞE BAŞLI AĞAÇ VİDASI (TRİFON)

HEXAGON HEAD WOOD SCREW

SECHSKANT-HOLZSCHRAUBE

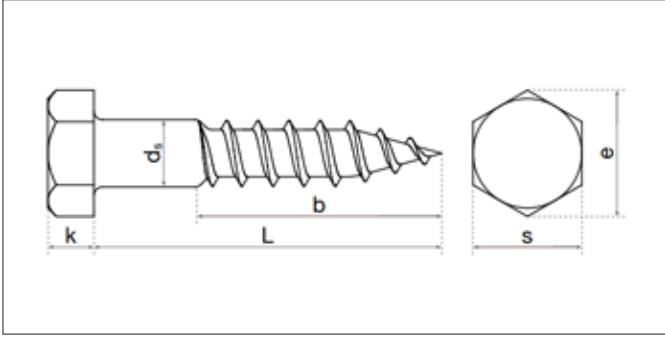

ISO	UNI	DIN
-	704	571 A2/A4
Mekanik Özellikler - Toleranslar Mechanical Properties - Tolerances Mechanische Eigenschaften - Toleranzen		ISO 3506-4 ISO 4759-1

TEKNİK BİLGİLER		TECHNICAL INFORMATIONS				TECHNISCHE INFORMATION	
d		5	6	8	10	12	
D _s	max	5	6	8	10	12	
	min	4,52	5,52	7,42	9,42	11,3	
k	nominal	3,5	4	5,5	7	8	
	max	3,88	4,38	5,88	7,45	8,45	
	min	3,13	3,63	5,13	6,55	7,55	
s	nominal	8	10	13	17	19	
	max	8	10	13	17	19	
	min	7,64	9,64	12,57	16,57	18,48	
e	min	8,63	10,89	14,2	18,72	20,88	

l	min	max	5	6	8	10	12
30	28,95	31,05	4,68	6,70			
35	33,75	36,25	5,18	7,51	14,37		
40	38,75	36,25	5,89	8,32	15,79	28,34	
45	43,75	46,25	6,51	9,05	17,10	30,36	
50	48,75	51,25	7,11	9,76	18,42	32,49	
60	58,50	61,50	8,33	11,33	21,15	36,94	52,42
70	68,50	71,50		12,90	23,88	41,19	58,49
80	78,50	81,50		14,44	26,68	45,74	65,27
90	88,25	91,75		15,90	29,75	50,50	71,85
100	98,25	101,75		17,54	32,38	54,65	78,00
110	108,25	111,75		19,09	35,22	54,67	84,40
120	118,25	121,75		20,64	38,00	57,16	90,57

INOX YUVARLAK BAŞLI DİBİ DÖRT KÖŞE CIVATA

MUSHROOM HEAD SQUARE NECK BOLTS

FLACHRUNDSCHRAUBE MIT VIERKANTANSATZ

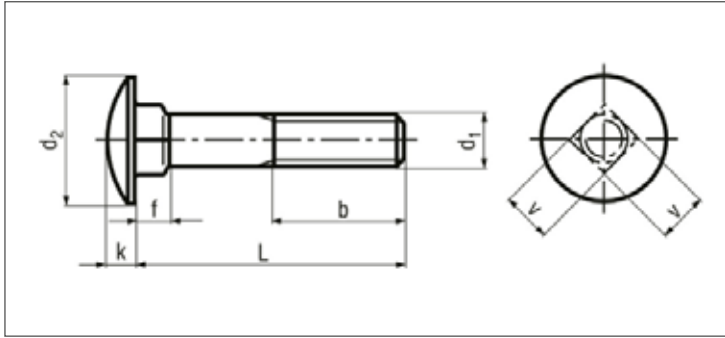

ISO	UNI	DIN
8677	5731	603 A2/A4
Mekanik Özellikler - Toleranslar Mechanical Properties - Tolerances Mechanische Eigenschaften - Toleranzen		ISO 3506-1 ISO 4759-1

TEKNİK BİLGİLER TECHNICAL INFORMATION TECHNISCHE INFORMATION

d		M5	M6	M8	M10	M12
p			1,00	1,25	1,50	1,75
k	max	3,30	3,88	4,88	5,38	6,95
	min	2,70	3,12	4,12	4,62	6,05
dk	max	13,55	16,55	20,65	24,65	30,65
	min	12,45	15,45	19,35	23,35	29,35
f	max	4,01	4,60	5,60	6,60	8,75
	min	2,90	3,40	4,40	5,40	7,25
v	max	5,48	6,48	8,58	10,58	12,70
	min	4,52	5,52	7,42	9,42	11,30
b	$l \leq 125$	16	18	22	26	30
	$l > 125$ ($125 < l \leq 200$)	22	24	28	32	36
	$l > 200$			41	45	49

l	min	max	M5	M6	M8	M10	M12
16	15,10	16,90	4,08	7,04	12,90		
20	18,95	21,05	4,59	7,75	14,00	23,20	39,70
22	21,58	22,42	4,67	8,10	14,80		
25	23,95	26,05	5,20	8,67	15,71	25,70	42,90
30	28,95	31,05	6,02	9,79	17,34	28,25	46,61
35	33,75	36,25	6,83	10,91	19,38	30,80	50,39
40	38,75	41,25	7,65	12,04	21,42	33,35	54,16
45	43,75	46,25	8,47	13,16	23,46	36,52	57,94
50	48,75	51,25	9,28	14,28	25,50	39,68	62,42
55	53,50	56,50	10,10	15,40	27,44	42,84	66,91
60	58,50	61,50	10,91	16,52	29,48	46,00	71,40
65	63,50	66,50	11,73	17,65	31,52	49,16	75,89
70	68,50	71,50	12,55	18,77	33,56	52,33	80,38
75	74,40	75,60		19,89	35,60	55,49	84,86
80	78,50	81,50		21,01	37,54	58,65	89,35
90	88,25	91,75		23,26	41,62	64,97	97,92
100	98,25	101,75			45,70	71,30	107,10

INOX SOKET BAŞLI İMBUS CIVATA

HEXAGON SOCKET HEAD CAP SCREWS

ZYLINDERSCHRAUBE MIT INNENSECHSKANT

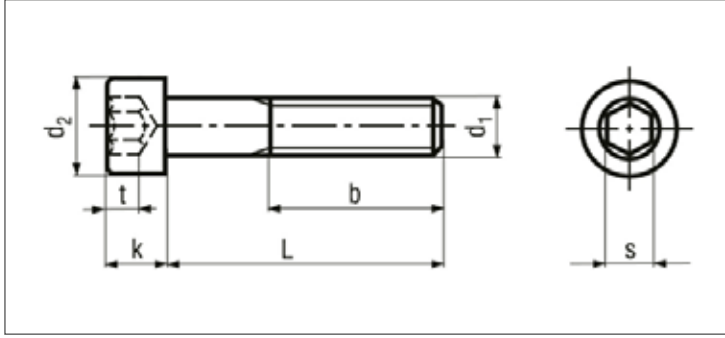

ISO	UNI	DIN
4762	5931	912 A2/A4
Mekanik Özellikler - Toleranslar Mechanical Properties - Tolerances Mechanische Eigenschaften - Toleranzen		ISO 3506-1 ISO 4759-1

TEKNİK BİLGİLER TECHNICAL INFORMATION TECHNISCHE INFORMATION

d		M3 ⁽¹⁾	M4 ⁽¹⁾	M5	M6	M8	M10	M12	M14	M16	M18	M20	M24
p		0,5	0,7	0,8	1,0	1,3	1,5	1,8	2,0	2,5	2,5	2,5	3
dk	max (Tırtılsız Başlı / Plain Heads)	5,5	7,0	8,5	10,0	13,0	16,0	18,0	21,0	24,0	27,0	30,0	36
	max (Tırtıl Başlı / Knurled Heads)	5,68	7,72	8,72	10,22	13,27	16,27	18,27	21,33	24,33	27,33	30,33	36,39
k	min	5,32	6,78	8,28	9,78	12,73	15,73	17,73	20,67	23,67	26,67	29,67	35,61
	max	3	4	5	6	8	10	12	14	16	18	20	24
s	min	2,86	3,82	4,82	5,70	7,64	9,64	11,57	13,57	15,57	17,57	19,48	23,48
	nominal	2,50	3,00	4,00	5,00	6,00	8,00	10,00	12,00	14,00	14,00	17,00	19
e	max	2,58	3,08	4,09	5,14	6,14	8,17	10,17	12,21	14,21	14,21	17,23	19,27
	min	2,52	3,02	4,02	5,02	6,02	8,02	10,02	12,03	14,03	14,03	17,05	19,06
t	min	2,87	3,44	4,58	5,72	6,86	9,15	11,43	13,72	16,00	16,00	19,44	21,73
b	min	1,30	2,00	2,50	3,00	4,00	5,00	6,00	7,00	8,00	9,00	10,00	12,00
L		18	20	22	24	28	32	36	40	44	48	52	60

l	min	max	M3	M4	M5	M6	M8	M10	M12	M14	M16	M18	M20	M24
6	5,76	6,24	0,72	1,52	2,23									
8	7,71	8,29	0,81	1,67	2,48	4,38								
10	9,71	10,29	0,89	1,82	2,73	4,76	10,40	18,10						
12	11,65	12,35	0,97	1,97	2,99	5,13	11,00	19,10						
14	13,65	14,35	1,06	2,13	3,24	5,51	11,60	20,10						
16	15,65	16,35	1,17	2,28	3,49	5,82	12,20	21,20	28,80					
18	17,58	18,42	1,28	2,48	3,74	6,19	13,50	22,20						
20	19,58	20,42	1,38	2,68	4,06	6,61	13,60	23,20	32,50	43,50	64,70			
22	21,58	22,42	1,48	2,93	4,37	6,98	14,20	24,20	34,30	45,50	67,70			
25	24,58	25,42	1,63	3,19	4,84	7,68	15,20	25,70	36,10	48,60	72,20			
30	29,58	30,42	1,88	3,69	5,62	8,40	17,10	28,20	39,80	53,60	78,70	112,30	129,50	
35	34,50	35,50	2,14	4,20	6,40	10,03	19,10	30,80	43,40	58,70	85,40	121,40	140,70	
40	39,50	40,50	2,39	4,71	7,18	11,13	21,20	33,30	47,10	63,80	92,10	130,50	151,80	273,00
45	44,50	45,50	2,64	5,21	7,95	12,25	23,20	36,50	50,70	68,80	98,80	139,70	162,90	288,00
50	49,50	50,50	2,89	5,72	8,73	13,36	25,20	39,80	55,20	73,90	107,30	148,80	174,00	304,00
55	54,40	55,60		6,22	9,51	14,47	27,20	43,00	59,60	78,90	115,40	157,90	185,20	320,00
60	59,40	60,60		6,73	10,32	15,58	29,20	46,20	64,20	85,00	123,50	167,00	196,30	334,00
65	64,40	65,60		7,24	11,13	16,20	31,40	49,50	68,60	91,10	131,60	176,10	207,00	349,00
70	69,40	70,60		7,74	11,94	17,81	33,40	52,70	72,20	97,20	139,70	185,20	219,00	367,00
75	74,40	75,60			12,75	18,92	35,40	56,00	76,70	103,20	147,80	195,30	231,00	384,00
80	79,40	80,60			13,56	20,00	37,40	59,20	81,20	109,30	155,80	205,40	244,00	404,00
85	84,30	85,70			14,37	21,20	37,70	62,40	85,70	115,40	163,90	215,60	255,00	421,00
90	89,30	90,70			15,18	22,30	41,80	65,70	90,20	121,40	172,00	225,70	269,00	440,00
100	99,30	100,70				24,50	45,90	72,10	99,20	133,60	188,20	245,90	294,00	477,00
110	109,30	110,70				26,70	50,00	78,40	108,20	145,70	204,40	266,20	320,00	513,00
120	119,30	120,70				28,90	54,10	84,80	117,20		220,60	286,40	345,00	550,00
130	129,20	130,80				31,20	67,00	91,20	126,50		236,80		370,00	
140	139,20	140,80					70,70	97,90	135,60		253,00			
150	149,20	150,80					74,30	103,90	144,70		269,20			
160	159,20	160,80							153,90		285,40			
170	169,20	170,80							163,00		301,60			
180	179,20	180,80							172,20		317,80			

INOX ALYAN BAŞLI SETSKUR

FLAT POINT HEXAGON SOCKET SET SCREWS

FLACHSPITZ-INNENSECHSKANT-STELLSCHRAUBEN

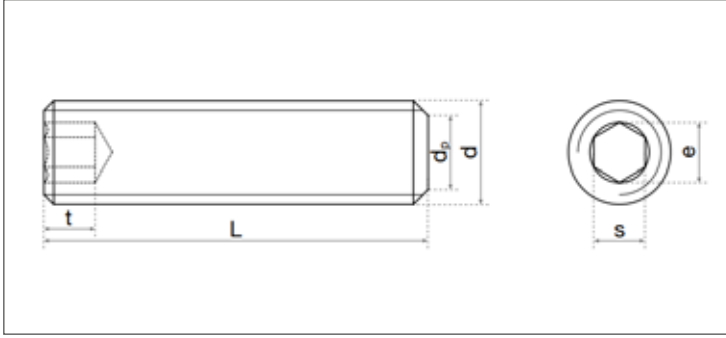

ISO	UNI	DIN
4026	5923	913 A2/A4
Mekanik Özellikler - Toleranslar Mechanical Properties - Tolerances Mechanische Eigenschaften - Toleranzen		ISO 3506-3 ISO 4759-1

TEKNIK BİLGİLER		TECHNICAL INFORMATION					TECHNISCHE INFORMATION			
d		M3	M4	M5	M6	M8	M10	M12	M14	M16
p		0,5	0,7	0,8	1	1,25	1,5	1,75	2	2
d _p	max	2	2,5	3,5	4	5,5	7	8,5	10	12
	min	1,75	2,25	3,2	3,7	5,2	6,64	8,14	9,64	11,57
s	nominal	1,5	2	2,5	3	4	5	6	6	8
	max	1,54	2,04	2,56	3,08	4,09	5,09	6,09	6,09	8,11
e	min	1,52	2,02	2,52	3,02	4,02	5,02	6,02	6,02	8,02
	min	1,73	2,3	2,87	3,44	4,58	5,72	6,86	6,86	9,15
t	3) min	1,2	1,5	2	2	3	4	4,8	5,6	6,4
	4) min	2	2,5	3	3,5	5	6	8	9	10

l	min	max	M3	M4	M5	M6	M8	M10	M12	M14	M16
3	2,80	3,20	0,10								
4	3,76	4,24	0,14	0,22							
5	4,76	5,24	0,18	0,31	0,31						
6	5,76	6,24	0,22	0,39	0,57	0,78					
8	7,71	8,29	0,32	0,54	0,82	1,13	1,93				
10	9,71	10,29	0,41	0,69	1,06	1,49	2,57	3,86			
12	11,65	12,35	0,50	0,85	1,31	1,85	3,21	4,88			
14	13,65	14,35	0,55	1,31	1,55	2,12	3,83	5,74	7,75		
16	15,65	16,35	0,68	1,15	1,80	2,56	4,50	6,92	9,79	13,30	15,80
20	19,48	20,42	0,87	1,46	2,28	3,58	5,78	8,94	12,65	17,30	21,90
25	24,58	25,42		1,85	2,90	4,17	7,41	11,42	16,32	22,40	28,60
30	29,58	30,42		2,23	3,51	5,07	9,03	13,97	19,99		35,30
35	34,50	35,50		2,62	4,12	5,97	10,61	16,52	23,66	32,60	41,90
40	39,50	40,50			4,73	6,86	12,24	19,07	27,34		48,70
45	44,50	45,50				7,76	13,84	21,60	31,01		55,30
50	49,50	50,50				8,66	15,45	24,14	34,68		62,00
60	59,40	60,60						29,22	42,02		
70	69,40	70,60						34,30	49,37		
80	79,40	80,60							56,71		

INOX ALYAN BAŞLI SİVRİ UÇLU SETSKUR

CONE POINT HEXAGON SOCKET SET SCREWS

KEGELSPITZEN-INNENSECHSKANT-STELLSCHRAUBEN

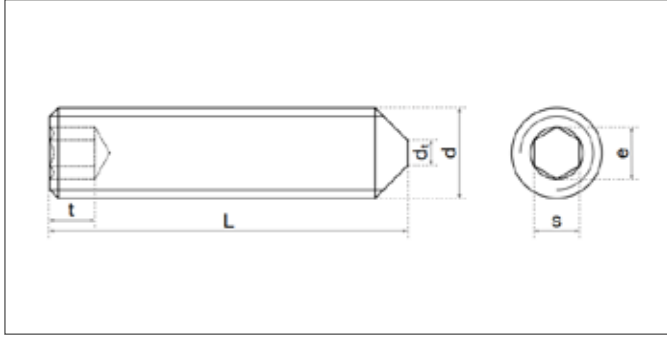

ISO	UNI	DIN
4027	5927	914 A2/A4
Mekanik Özellikler - Toleranslar Mechanical Properties - Tolerances Mechanische Eigenschaften - Toleranzen		ISO 3506-3 ISO 4759-1

TEKNIK BİLGİLER		TECHNICAL INFORMATIONS				TECHNISCHE INFORMATION		
d		M3	M4	M5	M6	M8	M10	M12
p		0,5	0,7	0,8	1	1,25	1,5	1,75
dt	max				1,5	2	2,5	3
	min				0,9	1,4	1,9	2,4
s	nominal	1,5	2	2,5	3	4	5	6
	max	1,54	2,04	2,56	3,08	4,09	5,09	6,09
	min	1,52	2,02	2,52	3,02	4,02	5,02	6,02
e	min	1,73	2,30	2,87	3,44	4,58	5,72	6,86
t	3) min	1,2	1,5	2	2	3	4	4,5
	4) min	2,0	2,5	3	3,5	5	6	8

l	min	max	M3	M4	M5	M6	M8	M10	M12
3	2,80	3,20							
4	3,76	4,24	0,13	0,22					
5	4,76	5,24	0,17	0,27	0,38				
6	5,76	6,24	0,21	0,35	0,59	0,70			
8	7,71	8,29	0,31	0,50	0,74	1,06	1,75		
10	9,71	10,29	0,40	0,65	0,99	1,42	2,40	3,50	
12	11,65	12,35	0,49	0,81	1,23	1,77	3,04	4,50	6,20
14	13,65	14,35	0,53	0,92	1,50	2,13	3,68	5,50	7,70
16	15,65	16,35	0,67	1,11	1,72	2,49	4,32	6,50	9,10
20	19,48	20,42	0,87	1,42	2,21	3,20	5,61	8,60	11,90
25	24,58	25,42	1,22	1,84	2,83	4,10	7,23	11,00	15,60
30	29,58	30,42	1,57	2,25	3,44	5,00	8,85	13,60	19,30
35	34,50	35,50				5,90	10,51	16,10	23,00
40	39,50	40,50				6,79	12,14	18,70	26,60
45	44,50	45,50				7,69	13,78	21,40	29,90
50	49,50	50,50				8,59	15,43	24,00	33,50
60	59,40	60,60					18,71		40,60

INOX DOG POINT SETSKUR

DOG POINT HEXAGON SOCKET SET SCREWS

DOG POINT INNENSECHSKANT-STELLSCHRAUBEN

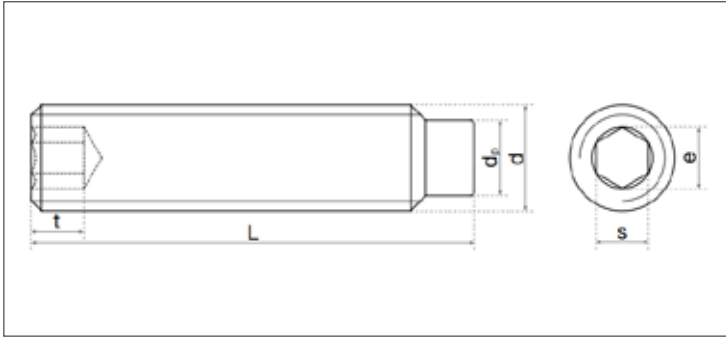

ISO	UNI	DIN
4028	5925	915 A2/A4
Mekanik Özellikler - Toleranslar Mechanical Properties - Tolerances Mechanische Eigenschaften - Toleranzen		ISO 3506-3 ISO 4759-1

TEKNİK BİLGİLER		TECHNICAL INFORMATION					TECHNISCHE INFORMATION	
d		M4	M5	M6	M8	M10	M12	
p		0,7	0,8	1	1,25	1,5	1,75	
dp	max	2,5	3,5	4	5,5	7	8,5	
	min	2,25	3,2	3,7	5,2	6,64	8,14	
s	nominal	2	2,5	3	4	5	6	
	max	2,04	2,56	3,06	4,09	5,09	6,09	
e	min	2,02	2,52	3,02	4,02	5,02	6,02	
	max	2,30	2,87	3,44	4,58	5,72	6,86	
t	3) min	1,5	2	2	3	4	4,8	
	4) min	2,5	3	3,5	5	6	8	
z (short dog point)	max	1,25	1,50	1,75	2,25	2,75	3,25	
	min	1	1,25	1,5	2	2,5	3	
z (long dog point)	max	2,25	2,75	3,25	4,3	5,3	6,3	
	min	2	2,5	3	4	5	6	

l	min	max	M4	M5	M6	M8	M10	M12
10	9,71	10,29	0,60	0,97	1,32	2,33	3,67	
12	11,65	12,35	0,76	1,21	1,66	2,73	4,50	6,18
14	13,65	14,35	0,88	1,43	1,92	3,18	4,60	7,38
16	15,65	16,35	1,06	1,70	2,39	4,02	6,17	9,09
20	19,48	20,42	1,37	2,19	3,10	5,30	8,18	11,22
25	24,58	25,42	1,73	2,81	4,00	6,93	14,89	14,89
30	29,58	30,42		3,48	4,90	8,55	18,56	18,59
35	34,50	35,50			5,79	10,17	22,24	22,24
40	39,50	40,50				11,83	25,91	25,91

INOX SETSKUR

CUP POINT HEXAGON SOCKET SET SCREWS

CUP POINT INNENSECHSKANT-STELLSCHRAUBEN

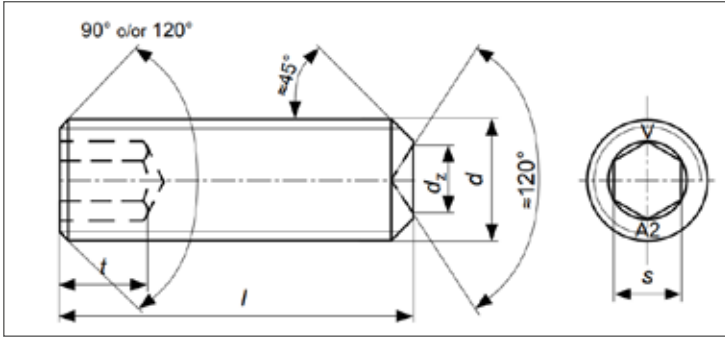

ISO	UNI	DIN
4029	5929	916 A2/A4
Mekanik Özellikler - Toleranslar Mechanical Properties - Tolerances Mechanische Eigenschaften - Toleranzen		ISO 3506-3 ISO 4759-1

TEKNIK BİLGİLER		TECHNICAL INFORMATIONS						TECHNISCHE INFORMATION	
d		M3	M4	M5	M6	M8	M10	M12	
p		0,5	0,7	0,8	1	1,25	1,5	1,75	
dv	max	1,4	2	2,5	3	5	6	8	
	min	1,15	1,75	2,25	2,75	4,7	5,7	7,64	
	nominal	1,5	2	2,5	3	4	5	6	
s	max	1,54	2,04	2,56	3,08	4,09	5,09	6,09	
	min	1,52	2,02	2,52	3,02	4,02	5,02	6,02	
e	min	1,73	2,3	2,87	3,44	4,58	5,72	6,86	
t	3) min	1,2	1,5	2	2	3	4	4,8	
	4) min	2	2,5	3	3,5	5	6	8	

l	min	max	M3	M4	M5	M6	M8	M10	M12
3	2,80	3,20	0,10						
4	3,76	4,24	0,14	0,24					
5	4,76	5,24	0,18	0,26	0,43				
6	5,76	6,24	0,22	0,39	0,55	0,76	1,22		
8	7,71	8,29	0,32	0,54	0,80	1,11	1,92		
10	9,71	10,29	0,41	0,69	1,04	1,47	2,57	3,80	
12	11,65	12,35	0,50	0,85	1,29	1,83	3,21	4,83	6,80
14	13,65	14,35	0,59	1,00	1,53	2,19	3,85	5,87	
16	15,65	16,35	0,68	1,15	1,78	2,54	4,50	6,88	9,70
20	19,48	20,42	0,87	1,46	1,25	3,26	5,78	8,90	12,60
25	24,58	25,42			2,88	4,16	7,41	11,40	16,20
30	29,58	30,42				5,06	9,03	14,00	19,90
35	34,50	35,50				5,96	10,63	16,60	23,60
40	39,50	40,50					12,26	19,10	27,30
45	44,50	45,50						21,70	30,40
50	49,50	50,50						24,10	33,90
60	59,40	60,60							41,00

INOX ALTİKÖŞE BAŞLI METRİK DIŞ YARIM PASO CIVATA

HEXAGON HEAD BOLT METRIC PARTIAL THREAD

SECHSKANTSCHRAUBE MIT SCHAFT

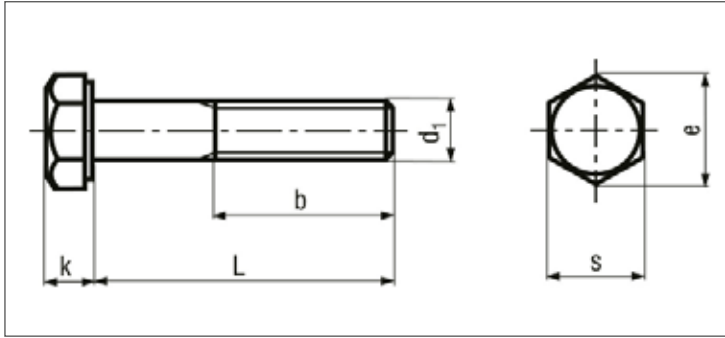

ISO	UNI	DIN
4014	5737	931 A2/A4
Mekanik Özellikler - Toleranslar Mechanical Properties - Tolerances Mechanische Eigenschaften - Toleranzen		ISO 3506-1 ISO 4759-1

TEKNİK BİLGİLER			TECHNICAL INFORMATION										TECHNISCHE INFORMATION		
d			M5	M6	M8	M10	M12	M14	M16	M18	M20	M22	M24	M27	M30
p			0,8	1	1,25	1,5	1,75	2	2	2,5	2,5	2,5	3	3	3,5
s	max		8	10	13	17	19	22	24	27	30	32	36	41	46
	Grade A	min	7,78	9,78	12,73	16,73	18,67	21,67	23,67	26,67	29,67	31,61	35,38		
	Grade B	min							23,16	26,16	29,18	31,00	35,00	40,00	45,00
k	nominal		3,5	4	5,3	6,4	7,5	8,8	10	11,5	12,5	14	15	17	18,7
	Grade A	max	3,35	3,85	5,15	6,22	7,32	8,62	9,82	11,28	12,28	13,78	14,78		
		min	3,65	4,15	5,45	6,58	7,68	8,98	10,18	11,72	12,72	14,22	15,55		
	Grade B	max							9,71	11,15	12,15	13,65	13,65	16,65	18,28
min								10,29	11,85	12,85	14,35	14,35	17,35	19,12	
e	Grade A	min	8,79	11,05	14,38	18,9	21,10	24,49	26,75	30,14	33,53	35,72	39,98		
	Grade B	min							26,17	29,56	32,95	35,03	39,55	45,20	50,85
b	≤ 125		16	18	22	26	30	34	38	42	46	50	54	60	66
	I > 125 (125 < I ≤ 200)		22	24	28	32	36	40	44	48	52	56	60	66	72
	I > 200					45	49	53	57	61	65	69	73	79	85

l	min	max	M5	M6	M8	M10	M12	M14	M16	M18	M20	M22	M24	M27	M30
25	24,58	25,42	4,91	7,06											
30	29,58	30,42	5,70	8,14											
35	34,50	35,50	6,49	9,22	18,39	32,26									
40	39,50	40,50	7,27	10,30	20,91	35,36	49,50								
45	44,50	45,50	8,06	11,42	22,43	38,39	54,15	76,27							
50	49,50	50,50	8,85	12,43	24,45	41,52	58,69	82,84	108,28	142,44					
55	54,40	55,60	9,64	13,54	26,06	44,25	63,24	89,00	116,38	152,54	196,99				
60	59,40	60,60	10,40	14,55	28,08	47,38	67,68	95,06	124,48	162,64	209,11	253,56	323,26		
65	64,40	65,60	11,21	15,66	30,10	50,51	71,02	99,81	132,57	172,74	221,23	268,71	341,44		
70	69,40	70,60	12,02	16,67	32,12	53,64	75,46	106,07	140,67	182,84	233,35	283,66	359,63	470,00	610,00
75	74,40	75,60	12,83	17,78	34,04	56,77	79,91	112,13	148,76	192,95	245,48	299,02	377,81	493,00	
80	79,40	80,60	13,64	18,79	36,06	59,90	84,45	118,19	156,89	202,04	257,60	314,17	395,99	516,00	665,00
85	84,30	85,70		19,90	38,08	63,04	88,90	124,25	164,96	212,14	269,72	329,32	414,18	539,00	
90	89,30	90,70		21,01	40,00	66,17	93,34	128,29	173,05	222,24	281,84	344,48	432,36	563,00	719,00
100	99,30	100,70		23,23	44,04	72,43	102,03	140,42	188,23	242,45	306,09	373,77	468,73	609,00	775,00
110	109,30	110,70		25,46	49,78	78,69	110,11	152,54	204,42	262,55	330,33	404,08	505,10	657,00	831,00
120	119,30	120,70		27,68	51,92	84,96	119,20	165,67	220,62	282,55	354,58	434,38	540,45	702,00	889,00
130	129,20	130,80		29,90	55,86	91,22	128,29	175,77	232,76	299,02	377,81	454,59	565,71	727,00	929,00
140	139,20	140,80		32,12	59,80	97,48	137,39	186,89	248,95	319,22	402,06	484,89	601,06	773,00	985,00
150	149,20	150,80		34,35	63,74	103,75	146,48	198,00	265,00	339,42	426,30	515,20	636,42	818,00	1.040,00
160	159,20	160,80			67,68	110,01	154,56	209,11	281,34	359,63	450,55	545,50	671,78	864,00	1.101,00
170	169,20	170,80			71,62	116,27	163,65	220,22	297,53	379,83	474,79	575,81	707,13	909,00	1.152,00
180	179,20	180,80			75,56	122,54	172,74	231,33	313,72	400,04	499,03	606,11	742,49	955,00	1.212,00
190	189,80	190,92				128,80	181,33	242,45	329,91	420,24	524,29	636,42	777,85	1.000,00	1.263,00
200	199,10	200,90				135,06	190,12	253,56	346,10	440,44	549,54	666,73	813,20	1.040,00	1.323,00

INOX ALTIKÖŞE BAŞLI METRİK DİŞ TAM PASO CIVATA

HEXAGON HEAD BOLT METRIC FULL THREAD

SECHSKANTSCHRAUBE MIT GEWINDE BIS KOPF

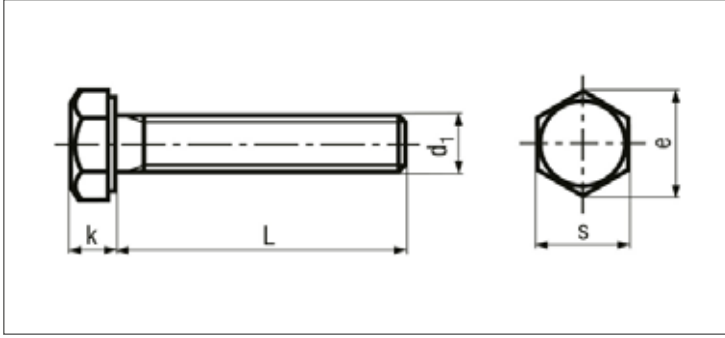

ISO	UNI	DIN
4017	5739	933 A2/A4
Mekanik Özellikler - Toleranslar Mechanical Properties - Tolerances Mechanische Eigenschaften - Toleranzen		ISO 3506-1 ISO 4759-1

TEKNİK BİLGİLER			TECHNICAL INFORMATION													TECHNISCHE INFORMATION				
d			M3	M4	M5	M6	M8	M10	M12	M14	M16	M18	M20	M22	M27	M30				
p			0,5	0,7	0,8	1	1,25	1,5	1,75	2	2	2,5	2,5	2,5	3	3,5				
s	max		5,5	7	8	10	13	17	19	22	24	27	30	32	41	46				
	Grade A	min	5,32	6,78	7,78	9,78	12,73	16,73	18,67	21,67	23,67	26,67	29,67	31,61						
	Grade B	min		6,64	7,64	9,64	12,57	16,57	18,48	21,16	23,16	26,15	29,16	31	40	45				
k	nominal		2	2,8	3,5	4	5,3	6,4	7,5	8,8	10	11,5	12,5	14	17	18,7				
	Grade A	max	2,12	2,92	3,65	4,15	5,45	6,56	7,68	8,98	10,18	11,72	12,72	14,22						
		min	1,88	2,68	3,35	3,85	5,15	6,22	7,32	8,62	9,82	11,28	12,28	13,78						
	Grade B	max		3,00	3,74	4,24	5,54	6,69	7,79	9,09	10,29	11,85	12,85	14,35	17,35	19,12				
min			2,6	3,26	3,76	5,06	6,11	7,21	8,51	9,71	11,15	12,15	13,65	16,65	18,28					
e	Grade A	min	6,01	7,66	8,79	11,05	14,38	18,9	21,10	24,49	26,75	30,14	33,53	35,72						
	Grade B	min		7,50	8,63	10,89	14,20	18,72	20,88	23,91	26,17	29,56	32,95	35,03	45,20	50,85				

l	min	max	M3	M4	M5	M6	M8	M10	M12	M14	M16	M18	M20	M22	M27	M30
6	5,76	6,24	0,69	1,35	2,15											
8	7,71	8,29	0,77	1,51	2,40	3,78		8,59								
10	9,71	10,29	0,85	1,66	2,66	4,12	9,19	16,37								
12	11,65	12,35	0,94	1,82	2,90	4,47	9,90	17,38								
14	13,65	14,35	1,03	1,97	3,15	4,82	10,51	18,39								
16	15,65	16,35	1,11	2,12	3,40	5,16	11,21	19,40	27,98							
18	17,65	18,35	1,19	2,28	3,66	5,52	11,82	20,41	29,40		61,42					
20	19,58	20,42	1,28	2,43	3,91	5,86	12,43	21,42	31,32	48,49	64,15					
22	21,58	22,42		2,59	4,16	6,21	13,03	22,43	33,34	50,51	66,88					
25	24,58	25,42	1,50	2,83	4,54	6,72	14,04	23,94	34,45	53,54	70,92	96,80	125,30			
30	29,58	30,42	1,72	3,22	5,16	7,59	15,66	26,47	38,08	58,49	77,68	105,10	135,40			
35	34,50	35,50	1,93	3,61	5,79	8,46	17,27	28,99	41,72	63,54	84,35	113,10	146,50			
40	39,50	40,50	2,15	4,00	6,41	9,32	18,89	31,52	45,36	68,59	91,12	121,20	156,60	195,00		
45	44,50	45,50	2,36	4,38	7,06	10,20	20,51	34,04	48,99	73,64	98,09	129,30	166,70	208,00		
50	49,50	50,50	2,59	4,78	7,67	11,11	22,02	36,57	52,53	78,69	104,05	137,40	177,80	221,00	381,00	
55	54,40	55,60			8,27	12,02	23,64	39,09	56,17	83,75	111,12	146,50	187,90	234,00	401,00	
60	59,40	60,60			8,89	12,83	25,26	41,72	58,79	88,70	118,19	154,60	198,00	246,00	420,00	549,00
65	64,40	65,60				13,74	26,87	44,25	63,44	93,75	124,25	163,00	209,00	260,00	439,00	572,00
70	69,40	70,60				14,55	28,49	46,77	67,08	98,80	131,33	171,00	219,00	272,00	459,00	596,00
75	74,40	75,60				15,46	30,10	49,30	70,71	103,04	138,40	179,00	229,00	285,00	478,00	620,00
80	79,40	80,60				16,37	31,72	51,82	74,35	108,09	145,47	188,00	240,00	298,00	497,00	643,00
85	84,30	85,70				17,17	33,34	54,35	77,99	113,14	151,53	196,00	250,00	311,00	517,00	668,00
90	89,30	90,70				18,08	34,95	56,87	81,62	118,19	158,60	204,00	261,00	324,00	536,00	692,00
100	99,30	100,70				19,81	38,08	61,93	88,90	128,30	171,73	220,00	282,00	350,00	575,00	739,00
110	109,30	110,70					41,32	67,08			185,88	237,00	303,00	375,00		
120	119,30	120,70					44,08	72,13			199,01	254,00	323,00	401,00		
130	129,20	130,80					46,84	77,18					343,00	425,00		
140	139,20	140,80						82,23					365,00	453,00		
150	149,20	150,80						87,28					385,00	478,00		
160	159,20	160,80											406,00			

INOX ALTİKÖŞE SOMUN

HEXAGON NUT

SECHSKANTMUTTERN

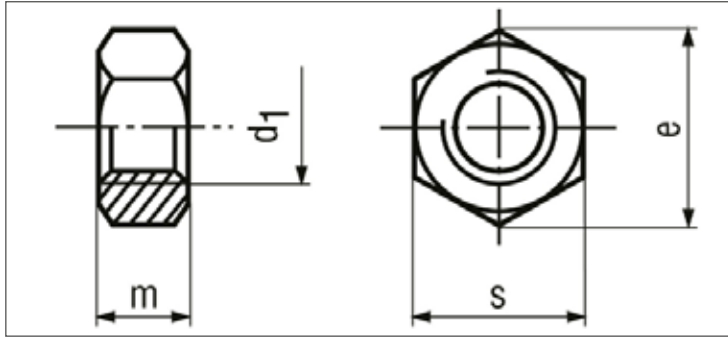

ISO	UNI	DIN
4032 (coarse thread) 8673 (fine thread)	5588	934 A2/A4
4032	5588	
<i>Mekanik Özellikler - Toleranslar</i> <i>Mechanical Properties - Tolerances</i> <i>Mechanische Eigenschaften - Toleranzen</i>		ISO 3506-2 ISO 4759-1

TEKNİK BİLGİLER TECHNICAL INFORMATIONS TECHNISCHE INFORMATION

d	s min	s max	m min	m max	e min	p	gr
M2	3,82	4	1,35	1,2	4,38	0,4	0,14
M2,5	4,82	5	1,75	2	5,45	0,45	0,28
M3	5,32	5,5	2,15	2,4	6,01	0,5	0,39
M4	6,78	7	2,9	3,2	7,66	0,7	0,82
M5	7,78	8	3,7	4	8,79	0,8	1,24
M6	9,78	10	4,7	5	11,05	1	2,53
M7	10,73	11	5,2	5,5	12,12	1	3,16
M8	12,73	13	6,14	6,5	14,38	1,25	5,30
M8	12,73	13	6,14	6,5	14,38	1	5,40
M10	16,73	17	7,64	8	18,90	1,5	11,70
M10	16,73	17	7,64	8	18,90	1,25	11,50
M10	16,73	17	7,64	8	18,90	1	11,50
M12	18,67	19	9,64	10	21,10	1,75	17,50
M12	18,67	19	9,64	10	21,10	1,5	17,20
M12	18,67	19	9,64	10	21,10	1,25	17,20
M14	21,67	22	10,3	11	24,49	2	25,30
M14	21,67	22	10,3	11	24,49	1,5	24,80
M16	23,67	24	12,3	13	26,75	2	33,70
M16	23,67	24	12,3	13	26,75	1,5	33,00
M18	26,16	27	14,3	15	29,56	2,5	50,00
M18	26,16	27	14,3	15	29,56	1,5	47,80
M20	29,16	30	14,9	16	32,95	2,5	65,20
M20	29,16	30	14,9	16	32,95	1,5	63,00
M22	31,00	32	16,9	18	35,03	2,5	80,00
M22	31,00	32	16,9	18	35,03	1,5	80,00
M24	35,00	36	17,7	19	39,55	3	111,00
M24	35,00	36	17,7	19	39,55	2	107,00
M27	40,00	41	20,7	22	45,20	3	167,00
M27	40,00	41	20,7	22	45,20	2	163,00
M30	45,00	46	22,7	24	50,85	3,5	226,00
M30	45,00	46	22,7	24	50,85	2	224,00
M33	49,00	50	24,7	26	55,37	3,5	291,00
M33	49,00	50	24,7	26	55,37	2	282,35
M36	53,80	55	27,4	29	60,79	4	398,00
M36	53,80	55	27,4	29	60,79	3	391,64
M39	58,80	60	29,4	31	66,44	4	508,00
M39	58,80	60	29,4	31	66,44	3	497,90
M42	63,10	65	32,4	34	72,09	4,5	660,00
M42	63,10	65	32,4	34	72,09	3	667,92

INOX INCE ALTIKÖŞE KONTRA SOMUN

HEXAGON THIN NUT

SECHSKANTMUTTERN NIEDRIG

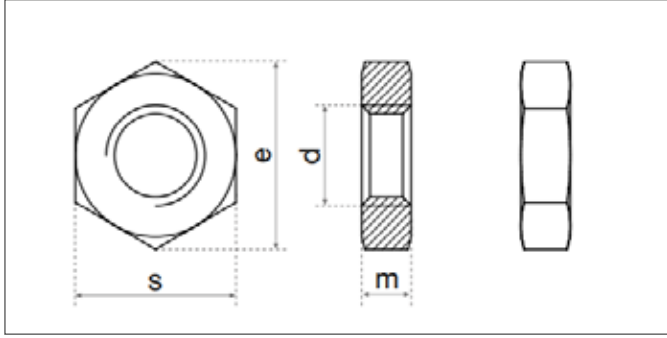

ISO	UNI	DIN
4035	5589	936 A2/A4
Mekanik Özellikler - Toleranslar Mechanical Properties - Tolerances Mechanische Eigenschaften - Toleranzen		ISO 3506-2 UNI 3740-4 ISO 4759-1

TEKNİK BİLGİLER	TECHNICAL INFORMATION	TECHNISCHE INFORMATION					
d	p	s min	s max	m min	m max	e min	gr
M3	0,5		5,5		2	6,01	0,26
M4	0,7		7		2,8	7,66	0,51
M5	0,8		8		3,5	8,79	0,77
M6	1,0		10		4	11,05	1,50
M7	1,0		11		4	12,12	2,28
M8	1,0	12,73	13	4,7	5	14,38	4,15
M8	1,3	12,73	13	4,7	5	14,38	4,05
M10	1,0	16,73	17	5,7	6	18,9	8,60
M10	1,3	16,73	17	5,7	6	18,9	8,60
M10	1,5	16,73	17	5,7	6	18,9	8,70
M12	1,3	18,67	19	6,64	7	21,1	12,04
M12	1,5	18,67	19	6,64	7	21,1	12,04
M12	1,8	18,67	19	6,64	7	21,1	12,25
M14	1,5	21,67	22	7,42	8	24,49	18,01
M14	2,0	21,67	22	7,42	8	24,49	18,42
M16	1,5	23,67	24	7,42	8	26,75	19,84
M16	2,0	23,67	24	7,42	8	26,75	20,34
M18	1,5	26,16	27	8,42	9	29,56	28,64
M18	2,5	26,16	27	8,42	9	29,56	30,00
M20	1,5	29,16	30	8,1	9	32,95	35,42
M20	2,5	29,16	30	8,1	9	32,95	36,70
M22	1,5	31	32	9,1	10	35,03	42,50
M22	2,5	31	32	9,1	10	35,03	44,30
M24	2,0	35	36	9,1	10	39,55	56,47
M24	3,0	35	36	9,1	10	39,55	58,70
M27	2,0	40	41	10,9	12	45,2	88,04
M27	3,0	40	41	10,9	12	45,2	91,10
M30	2,0	45	46	10,9	12	50,85	111,30
M30	3,5	45	46	10,9	12	50,85	111,30
M33	2,0	49	50	12,9	14	55,37	151,80
M33	3,5	49	50	12,9	14	55,37	156,90
M36	3,0	53,8	55	12,9	14	60,79	189,20
M36	4,0	53,8	55	12,9	14	60,79	192,30
M39	3,0	58,8	60	14,9	16	66,44	257,00
M39	4,0	58,8	60	14,9	16	66,44	263,10
M42	3,0	63,1	65	14,9	16	71,3	304,00
M42	4,5	63,1	65	14,9	16	71,3	311,00
M45	4,5	68,1	70	16,9	18	76,95	405,00
M48	5,0	73,1	75	16,9	18	82,6	466,00
M52	5,0	78,1	80	18,7	20	88,25	587,00
M56	5,5		85		22	93,56	719,00

INOX HAVŞA BAŞLI METRİK VİDA

COUNTERSUNK SLOTTED FLAT HEAD SCREWS

SENKSCHRAUBEN MIT SCLITZ

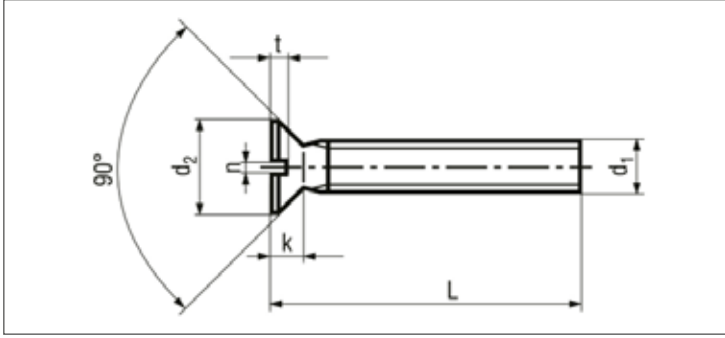

ISO	UNI	DIN
2009	6109	963 A2/A4
Mekanik Özellikler - Toleranslar Mechanical Properties - Tolerances Mechanische Eigenschaften - Toleranzen		ISO 3506-1 ISO 4759-1

TEKNİK BİLGİLER		TECHNICAL INFORMATIONS					TECHNISCHE INFORMATION			
d		M2	M2,5	M3	M4	M5	M6	M8	M10	
dk	max	3,8	4,7	5,6	7,5	9,2	11	14,5	18	
	min	3,5	4,4	5,3	7,14	8,84	10,57	14,07	17,57	
k	max	1,2	1,5	1,65	2,2	2,5	3	4	5	
	nominal	0,5	0,6	0,8	1	1,2	1,6	2	2,5	
n	max	0,70	0,80	1,00	1,20	1,51	1,91	2,31	2,81	
	min	0,56	0,66	0,86	1,06	1,26	1,66	2,06	2,56	
t	max	0,6	0,7	0,85	1,1	1,3	1,6	2,1	2,6	
	min	0,4	0,5	0,6	0,8	1	1,2	1,6	2	

l	min	max	M2	M2,5	M3	M4	M5	M6	M8	M10
4	3,75	4,25	0,12							
5	4,75	5,25	0,14		0,34					
6	5,75	6,25	0,16	0,27	0,39	0,93	1,34			
8	7,70	8,30	0,20	0,33	0,48	1,09	1,52	2,44		
10	9,70	10,30	0,24	0,40	0,57	1,25	1,77	2,80	5,83	
12	11,65	12,35	0,28	0,46	0,66	1,41	2,01	3,16	6,49	9,80
14	13,65	14,35	0,31	0,52	0,75	1,57	2,26	3,52	7,15	10,89
16	15,65	16,35	0,35	0,58	0,84	1,73	2,51	3,88	7,81	11,91
20	19,60	20,40	0,43	0,71	1,02	2,05	3,00	4,60	9,12	13,97
25	24,60	25,40		0,86	1,25	2,45	3,62	5,50	10,78	16,53
30	29,60	30,40			1,48	2,86	4,23	6,40	12,43	19,20
35	34,50	35,50			1,70	3,26	4,85	7,30	14,07	21,77
40	39,50	40,50			1,93	3,66	5,46	8,20	15,71	24,34
45	44,50	45,50			2,16	4,06	6,08	9,04	17,36	26,91
50	49,50	50,50			2,38	4,46	6,70	9,99	19,00	29,58
55	54,00	56,00				4,86	7,31	10,89	20,64	32,15
60	59,00	61,00				5,26	7,93	11,81	22,29	34,71
65							8,54	12,71	23,93	37,28
70	69,00	71,00					9,16	13,62	25,57	39,95
75							9,78	14,53	27,22	42,52
80	79,00	81,00					10,39	15,44	28,86	45,09

INOX MERCİMEK BAŞLI METRİK VİDA

COUNTERSUNK SLOTTED RAISED HEAD SCREWS

LINSENKOPFSCHRAUBEN MIT SCHLITZ

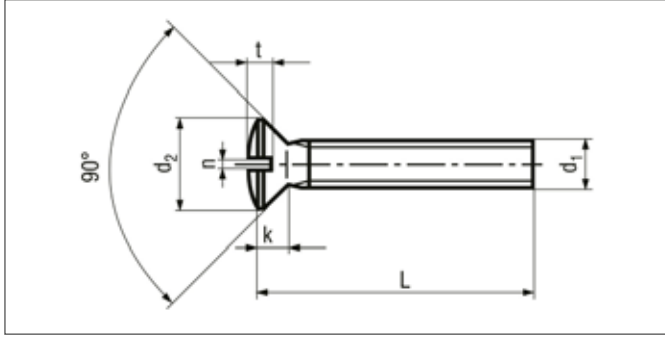

ISO	UNI	DIN
2010	6110	964 A2/A4
Mekanik Özellikler - Toleranslar Mechanical Properties - Tolerances Mechanische Eigenschaften - Toleranzen		ISO 3506-1 ISO 4759-1

TEKNIK BİLGİLER		TECHNICAL INFORMATIONS					TECHNISCHE INFORMATION			
d		M2	M2,5	M3	M4	M5	M6	M8	M10	
dk	max	3,8	4,7	5,6	7,5	9,2	11	14,5	18	
	min	3,5	4,4	5,3	7,14	8,84	10,57	14,07	17,57	
k	max	1,2	1,5	1,65	2,2	2,5	3	4	5	
	nominal	0,5	0,6	0,8	1	1,2	1,6	2	2,5	
n	max	0,70	0,80	1,00	1,20	1,51	1,91	2,31	2,81	
	min	0,56	0,66	0,86	1,06	1,26	1,66	2,06	2,56	
t	max	1,00	1,20	1,45	1,90	2,30	2,80	3,70	4,60	
	min	0,8	1	1,2	1,6	2	2,4	3,2	4	

l	min	max	M2	M2,5	M3	M4	M5	M6	M8	M10
4	3,75	4,25		0,31	0,53					
5	4,75	5,25	0,20	0,34	0,58					
6	5,75	6,25	0,22	0,37	0,62	1,20	2,11			
8	7,70	8,30	0,26	0,43	0,71	1,37	2,36	3,66		
10	9,70	10,30	0,30	0,50	0,80	1,51	2,62	4,03	8,06	
12	11,65	12,35	0,34	0,56	0,89	1,67	2,88	4,39	8,72	14,99
14	13,65	14,35	0,37	0,62	0,98	1,84	3,13	4,74	9,38	16,02
16	15,65	16,35	0,41	0,67	1,07	2,00	3,39	5,11	10,03	17,05
20	19,60	20,40	0,49	0,80	1,25	2,33	3,90	5,85	11,30	19,10
25	24,60	25,40	0,59	0,96	1,48	2,71	4,52	6,74	12,94	21,67
30	29,60	30,40			1,70	3,10	5,16	7,65	14,58	24,24
35	34,50	35,50			1,93	3,50	5,77	8,47	16,23	26,80
40	39,50	40,50			2,16	3,90	6,42	9,45	17,87	29,37
45	44,50	45,50			2,38	4,30	7,07	10,27	19,41	31,94
50	49,50	50,50			2,61	4,70	7,70	11,19	21,16	34,51
55	54,00	56,00			2,83	5,10	8,35	12,12	22,70	37,07
60	59,00	61,00			3,06	5,50	8,99	13,04	24,34	39,64
70	69,00	71,00					10,27	14,89	27,52	44,78
80	79,00	81,00					11,56	16,74	30,60	49,91

INOX YILDIZ HAVŞA BAŞLI METRİK VİDA

CROSS RECESSED COUNTERSUNK HEAD SCREWS

SENKKOPFSCHRAUBE MIT KREUZ

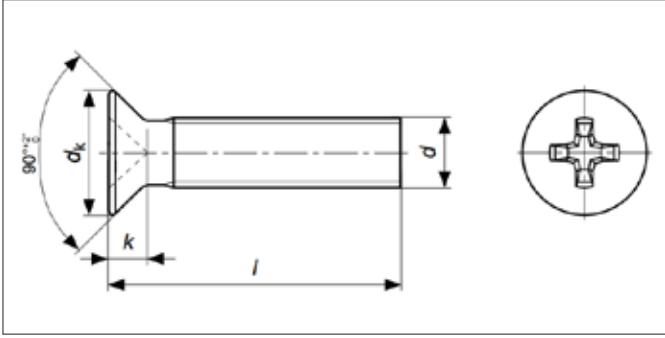

ISO	UNI	DIN
7046	7688	965 A2/A4
Mekanik Özellikler - Toleranslar Mechanical Properties - Tolerances Mechanische Eigenschaften - Toleranzen		ISO 3506-1 ISO 4759-1

TEKNIK BİLGİLER		TECHNICAL INFORMATIONS					TECHNISCHE INFORMATION			
d		M2	M2,5	M3	M4	M5	M6	M8	M10	
dk	max	3,8	4,7	5,6	7,5	9,2	11	14,5	18	
	min	3,5	4,4	5,3	7,14	8,84	10,57	14,07	17,17	
k	max	1,2	1,5	1,65	2,2	2,5	3	4	5	
N°	v	1			2		3	4		
m	≈	2,35	2,7	2,9	4,4	4,6	6,8	8,7	9,6	
Soket Derinliği H Penetration Depth H	max	1,25	1,55	1,8	2,4	2,6	3,3	4,4	5,3	
	min	0,95	1,25	1,5	1,9	2,1	2,8	3,9	4,8	

l	min	max	M2	M2,5	M3	M4	M5	M6	M8	M10
4	3,75	4,25	0,12		0,30					
5	4,75	5,25	0,14	0,24	0,34	0,85				
6	5,75	6,25	0,16	0,27	0,39	0,93				
8	7,7	8,3	0,20	0,33	0,48	1,09	1,52	2,44		
10	9,7	10,3	0,24	0,40	0,57	1,25	1,77	2,80	5,83	
12	11,65	12,35	0,28	0,46	0,66	1,41	2,01	3,15	6,49	
14	13,65	14,35	0,31	0,52	0,75	1,57	2,26	3,52	7,15	
16	15,65	16,35	0,35	0,58	0,84	1,73	2,51	3,88	7,81	11,91
18	17,65	18,35			0,93	1,88	2,75	4,24		
20	19,6	20,4	0,43	0,71	1,02	2,05	3	4,60	9,12	13,97
22	21,6	22,4			1,12	2,23	3,25	4,96		
25	24,6	25,4		0,86	1,25	2,45	3,62	5,50	10,78	16,53
30	29,6	30,4			1,48	2,86	4,23	6,40	12,43	19,20
35	34,5	35,5			1,70	3,26	2,85	7,30	14,07	21,77
40	39,5	40,5			1,93	3,66		8,20	15,71	24,34
45	44,5	45,5			2,16	4,06	6,08	9,10	17,36	26,91
50	49,5	50,5			2,38	4,46	6,71	9,99	19	29,58
55	54	56			2,61	4,86	7,31	10,89	20,64	32,15
60	59	61				5,26	7,93	11,81	22,29	34,71
70	69	71				6,06	9,16	13,62	25,57	
80	79	81					10,4	15,45	28,86	
90							11,63	17,27	32,15	
100								19,10	35,43	

INOX YILDIZ MERCİMEK BAŞLI METRİK VİDA

CROSS RECESSED COUNTERSUNK RAISED HEAD SCREWS

LINSENENKSRUBEN MIT KREUZSCHLITZ

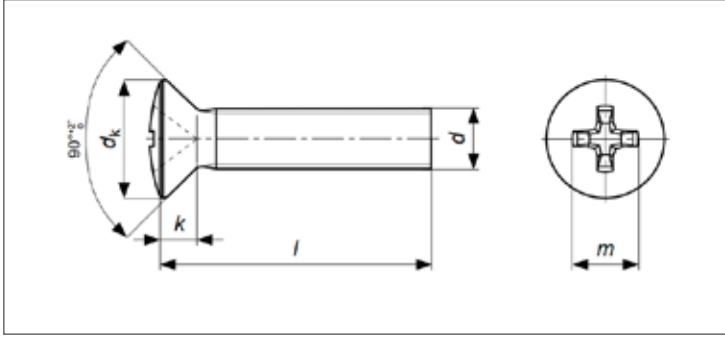

ISO	UNI	DIN
7047	7689	966 A2/A4
Mekanik Özellikler - Toleranslar Mechanical Properties - Tolerances Mechanische Eigenschaften - Toleranzen		ISO 3506-1 ISO 4759-1

TEKNİK BİLGİLER		TECHNICAL INFORMATION			TECHNISCHE INFORMATION	
d		M3	M4	M5	M6	M8
dk	max	5,6	7,5	9,2	11	14,5
	min	5,3	7,14	8,84	10,57	14,07
k	max	1,65	2,2	2,5	3	4
N°	Phillips Recess No	1	2		3	4
	PH Drv No					
m	≈	3,1	4,5	5,3	6,8	9
Soket Derinliği H Penetration Depth H	max	2	2,54	3,27	3,53	4,68
	min	1,7	2,04	2,77	3,03	4,18

l	min	max	M3	M4	M5	M6	M8
4	3,75	4,25	0,36				
5	4,75	5,25	0,41	1,02			
6	5,75	6,25	0,45	1,10	1,53		
8	7,70	8,30	0,54	1,26	1,79	2,87	
10	9,70	10,30	0,63	1,43	2,02	3,22	7,08
12	11,65	12,35	0,72	1,58	2,27	3,58	7,73
14	13,65	14,35	0,81	1,75	2,52	3,94	8,39
16	15,65	16,35	0,90	1,90	2,76	4,30	9,05
18	17,65	18,35		2,05	3,01		
20	19,60	20,40	1,09	2,21	3,26	5,02	10,37
22	21,60	22,40		2,36	3,50		
25	24,60	25,40	1,31	2,63	3,87	5,93	12,02
30	29,60	30,40	1,54	3,03	4,49	6,82	13,66
35	34,50	35,50		3,43	5,10	7,72	15,30
40	39,50	40,50		3,83	5,72	8,62	16,95
45	44,50	45,50		4,23	6,33	9,52	18,59
50	49,50	50,50		4,63	6,94	10,37	20,23
55	54,00	56,00			7,56	11,30	21,88
60	59,00	61,00			8,17	12,22	23,52
65	64,00	66,00			8,79	13,11	
70	69,00	71,00			9,41	14,01	
80	79,00	81,00				15,82	
90						17,63	
100						19,43	

INOX GİJON

THREADAD RODS

GEWINDESTANGE

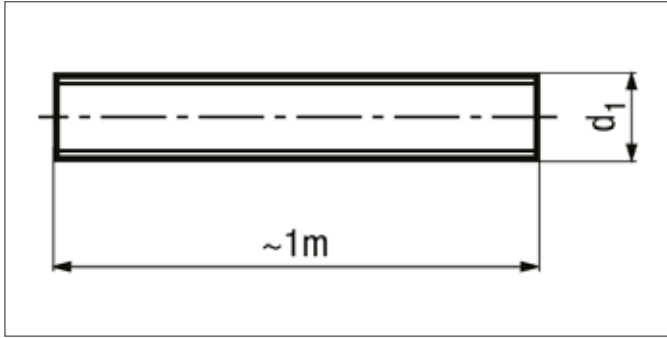

ISO	UNI	DIN
-	6547	975 A2/A4
<i>Mekanik Özellikler - Toleranslar</i> <i>Mechanical Properties - Tolerances</i> <i>Mechanische Eigenschaften - Toleranzen</i>		ISO 3506-1 ISO 4759-1

	TEKNİK BİLGİLER					TECHNICAL INFORMATIONS					TECHNISCHE INFORMATION			
d	M3	M4	M5	M6	M8	M10	M12	M14	M16	M18	M20	M22	M24	
p	0,50	0,50	0,80	1,00	1,25	1,50	1,75	2,00	2,00	2,50	2,50	2,50	3,00	
gr	44,5	78,9	125,5	179,1	313,7	496,9	720,5	986,7	1325,7	1646,5	2076,6	2556,3	2991,5	

d	M27	M30	M33	M36	M39									
p	3,00	3,50	3,50	4,00	4,00									
gr	3.866,85	4.941,60	5.827,10	6.885,65	8.182,02									

INOX ALTIKÖŞE YÜKSEK FİBERLİ SOMUN

NYLON INSERT HIGH HEX LOCK NUT

SECHSKANTMUTTER MIT NICHTMETALLISCHEM KLEMMTEIL, HOCH

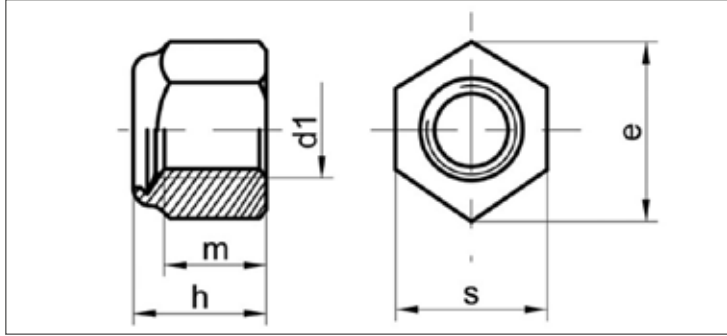

ISO	UNI	DIN
7040	7473	982 A2/A4
Mekanik Özellikler - Toleranslar Mechanical Properties - Tolerances Mechanische Eigenschaften - Toleranzen		ISO 3506-2 UNI 3740-4 ISO 4759-1

TEKNİK BİLGİLER		TECHNICAL INFORMATIONS			TECHNISCHE INFORMATION			
d	p	s min	s max	e min	h min	h max	m min	gr
M3	0,5		5,5			4,02		
M4	0,7		7	7,74		5,8	3,2	1,06
M5	0,8	7,78	8	8,79	6	6,3	4,4	1,62
M6	1	9,78	10	11,05	7,7	8	4,9	2,96
M7	1	10,73	11	12,12	8,2	8,5	6,14	3,88
M8	1	12,73	13	14,38	9,14	9,5	6,5	6,3
M8	1,25	12,73	13	14,38	9,14	9,5	6,5	6,41
M10	1,25	16,73	17	18,9	11,14	11,5	8,04	13,76
M10	1,5	16,73	17	18,9	11,14	11,5	8,04	
M12	1,25	18,67	19	21,1	13,64	14	10,37	19,13
M12	1,75	18,67	19	21,1	13,64	14	10,37	19,53
M14	1,5	21,67	22	24,49	15,3	16	12,1	28,94
M14	2	21,67	22	24,49	15,3	16	12,1	29,55
M16	1,5	23,67	24	26,75	17,3	18	12,8	37,44
M16	2	23,67	24	26,75	17,3	18	12,8	38,15
M18	1,5	26,16	27	29,56	19,16	20	14,1	53,03
M18	2,5	26,16	27	29,56	19,16	20	14,1	54,65
M20	1,5	29,16	30	32,95	20,7	22	16,9	71,24
M20	2,5	29,16	30	32,95	20,7	22	16,9	73,47
M22	1,5	31	32	35,03	23,7	25	18,1	85,51
M22	2,5	31	32	35,03	23,7	25	18,1	88,55
M24	2	35	36	39,55	26,7	28	20,2	123,5
M24	3	35	36	39,55	26,7	28	20,2	126,5
M27	2		41	45,63		31	21,6	181,1
M27	3		41	45,63		31	21,6	185,2
M30	2		46	51,28		33	24	261,1
M30	3,5		46	51,28		33	24	261,1

INOX ALTİKÖŞE FİBERLİ SOMUN

HEXAGON NYLON INSERT NUT

SECHSKANTMUTTERN MIT NICHTMETALLISCHEM KLEMMTEIL

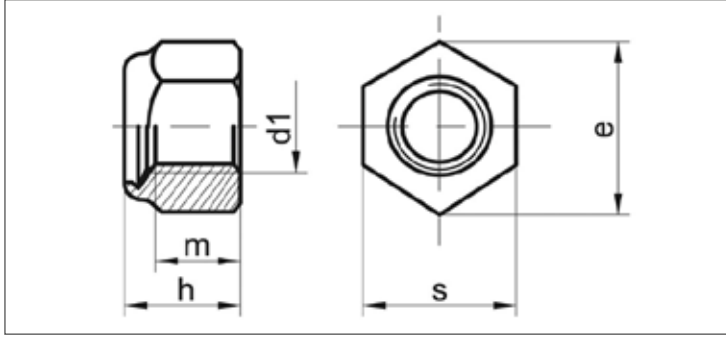

ISO	UNI	DIN
10511	7474	985 A2/A4
Mekanik Özellikler - Toleranslar Mechanical Properties - Tolerances Mechanische Eigenschaften - Toleranzen		ISO 3506-2 ISO 4759-1

TEKNIK BİLGİLER	TECHNICAL INFORMATION	TECHNISCHE INFORMATION
-----------------	-----------------------	------------------------

d	p	s min	s max	e min	h min	h max	m min	gr
M3	0,5	5,32	5,5	6,01	3,7	4	2,4	0,5
M4	0,7	6,78	7	7,66	4,7	5	2,9	1
M5	0,8	7,78	8	8,79	4,7	5	3,2	1,4
M6	1	9,78	10	11,05	5,7	6	4	2,4
M7	1	10,73	11	12,12	7,14	7,5	4,7	3
M8	1	12,73	13	14,38	7,64	8	5,5	5,1
M8	1,25	12,73	13	14,38	7,64	8	5,5	5,2
M10	1,25	15,73	17	18,9	9,64	10	6,5	10,5
M10	1,5	15,73	17	18,9	9,64	10	6,5	10,7
M12	1,25	18,67	19	21,1	11,57	12	8	17,1
M12	1,75	18,67	19	21,1	11,57	12	8	17,4
M14	1,5	21,67	22	24,49	13,3	14	9,5	25,8
M14	2	21,67	22	24,49	13,3	14	9,5	26,4
M16	1,5	23,67	24	26,75	15,3	15	10,5	33,8
M16	2	23,67	24	26,75	15,3	15	10,5	34,5
M18	1,5	26,16	27	29,56	17,66	16	13	44,7
M18	2,5	26,16	27	29,56	17,66	16	13	45,6
M20	1,5	29,16	30	32,95	18,7	17,5	14	64,6
M20	2,5	29,16	30	32,95	18,7	17,5	14	65,9
M22	1,5	31	32	35,03	20,7	19	15	74,5
M22	2,5	31	32	35,03	20,7	19	15	76,1
M24	2	35	36	39,55	22,7	21	15	99,4
M24	3	35	36	39,55	22,7	21	15	101,4
M27	2	40	41	45,2	25,7	22,5	17	161
M27	3	40	41	45,2	25,7	22,5	17	164,3
M30	2	45	46	50,85	28,7	24,5	19	210,7
M30	3,5	45	46	50,85	28,7	24,5	19	215

INOX YARIKLI PİM

HEAVY DUTY SPRING PINS

SPANNSTIFTE

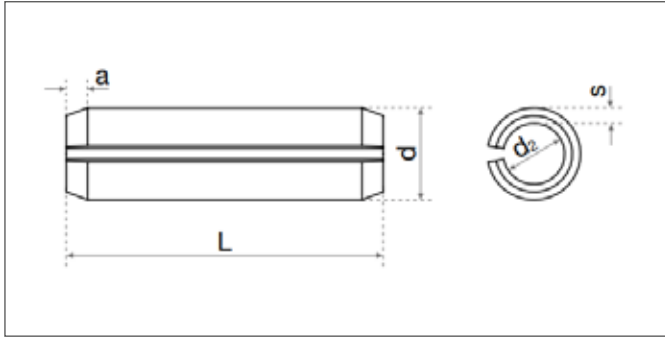

ISO	UNI	DIN
8752	6873	1481 A2/A4
Mekanik Özellikler - Toleranslar Mechanical Properties - Tolerances Mechanische Eigenschaften - Toleranzen		ISO 3506-3 UNI 6830

TEKNIK BİLGİLER		TECHNICAL INFORMATIONS						TECHNISCHE INFORMATION			
d		1,5	2	2,5	3	3,5	4	5	6	8	10
d1	max	1,80	2,40	2,90	3,50	4,00	4,60	5,60	6,70	8,80	10,80
	min	1,7	2,3	2,8	3,3	3,8	4,4	5,4	6,4	8,50	10,50
d2	≈	1,10	1,50	1,80	2,10	2,30	2,80	3,40	3,9	5,5	6,50
s	≈	0,30	0,40	0,50	0,60	0,75	0,80	1,00	1,25	1,50	2,00
a	≈	0,25	0,35	0,40	0,50	0,60	0,65	0,90	1,20	2,00	2,00

d		1,5	2	2,5	3	3,5	4	5	6	8	10
6	+ 0,5 0				0,204		0,358	0,566			
8		0,068			0,272		0,478	0,754	1,10		
10		0,085	0,153		0,340		0,597	0,942	1,38		
12		0,103	0,184	0,283	0,408		0,717	1,130	1,66		
14			0,214	0,330	0,476		0,836	1,318	1,94	3,13	
16		0,244	0,377	0,544		0,956	1,506	2,22	3,58		
18		0,275	0,424	0,612	0,887	1,075	1,694	2,50	4,03		
20		0,305	0,471	0,680	0,985	1,195	1,882	2,78	4,47		
22			0,518	0,748	1,084	1,314	2,070	3,06	4,92		
24	+ 1 0		0,565	0,816	1,182	1,434	2,258	3,34	5,37		
26				0,884	1,281	1,553	2,446	3,62	5,82		
28				0,952	1,379	1,673	2,634	3,90	6,27		
30					1,020	1,478	1,792	2,822	4,18	6,72	
32					1,088	1,576	1,912	3,01	4,46	7,17	
36					1,224		2,18	3,39	4,98	8,06	
40					1,360		2,39	3,77	5,54	8,95	
45							2,68	4,24	6,23	10,10	
50							2,98	4,71	6,92	11,20	18,40
55		+ 1,5 0					3,27	5,18	7,61	12,33	20,30
60						3,57	5,65	8,30	13,46	22,13	
70						4,16	6,59		15,71	25,83	
80						4,75	7,53		17,96	29,53	
90							8,45		20,56	33,20	
100							9,37		22,40	36,90	

INOX KÖR SOMUN

HEX DOMED CAP NUT

SECHSKANT HUTMUTTERN

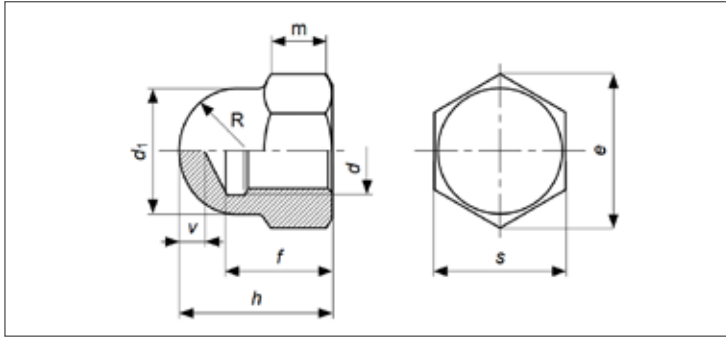

ISO	UNI	DIN
-	5721	1587 A2/A4
Mekanik Özellikler - Toleranslar Mechanical Properties - Tolerances Mechanische Eigenschaften - Toleranzen		ISO 3506-2 ISO 4759-1

TEKNIK BİLGİLER TECHNICAL INFORMATION TECHNISCHE INFORMATION

d		d1	s min		s max		e min	f min	f max	h min	h max	R ≈	v min	gr			
M3		5				5,5	6,08		4		5		2,5	1	1,01		
M4	Grade A	6,5		6,78		7	7,66	5,26	5,74	7,64	8		3,25	2	1,52		
M4	Grade B	6,5		6,64		7	7,5	5,26	5,74	7,42	8		3,25	2	1,52		
M5	Grade A	7,5		7,78		8	8,79	7,21	7,79	9,64	10		3,75	2	2,53		
M5	Grade B	7,5		7,64		8	8,63	7,21	7,79	9,42	10		3,75	2	2,53		
M6	Grade A	9,5		9,64		10	11,05	7,71	8,29	11,57	12		4,75	2	4,72		
M6	Grade B	9,5		9,78		10	10,89	7,71	8,29	11,30	12		4,75	2	4,72		
M8	Grade A	12,5		12,73		13	14,38	10,56	11,35	14,57	15		6,25	2	11,13		
M8	Grade B	12,5		12,57		13	14,2	10,56	11,35	14,30	15		6,25	2	11,13		
M10	Grade A	15	16	15,73	16,73	16	17	17,77	18,9	12,65	13,35	17,57	18	7,5	8	2	20,34
M10	Grade B	15	16	15,57	16,57	16	17	17,59	18,72	12,65	13,35	17,30	18	7,5	8	2	20,34
M12	Grade A	17	18	17,73	18,67	18	19	20,03	21,1	15,65	16,36	21,48	22	8,5	9	3	28,64
M12	Grade B	17	18	17,57	18,48	18	19	19,85	20,88	15,65	16,36	21,16	22	8,5	9	3	28,64
M14	Grade A	20	21	20,67	21,67	21	22	23,35	24,49	17,65	18,35	24,48	25	10	10,5	4	40,70
M14	Grade B	20	21	20,16	21,16	21	22	22,78	23,91	17,65	18,35	24,16	25	10	10,5	4	40,70
M16	Grade A	23		23,67		24		26,75	20,58	21,42	27,48	28		11,5	4	54,95	
M16	Grade B	23		23,16		24		26,17	20,58	21,42	27,16	28		11,5	4	54,95	
M18	Grade A	26		26,16		27		30,14	24,58	25,42	31,38	32		13	5	96,14	
M18	Grade B	26		26,67		27		29,59	24,58	25,42	31,00	32		13	5	96,14	
M20	Grade A	28		29,67		30		33,53	25,58	26,42	33,38	34		14	5	105,20	
M20	Grade B	28		29,16		30		32,95	25,58	26,42	33,00	34		14	5	105,20	
M22	Grade A	31	33	31,61	33,38	32	34	35,72	37,72	28,58	29,42	38,38	39	15,5	16,5	5	130,50
M22	Grade B	31	33	31	33	32	34	35,03	37,29	28,58	29,42	38,00	39	15,5	16,5	5	130,50
M24	Grade A	34	35,38			36		39,98	30,5	31,5	41,38	42		17	6	218,60	
M24	Grade B	34	35			36		39,55	30,5	31,5	41,00	42		17	6	218,60	

INOX ALTİKÖŞE BAŞLI FLANŞLI CIVATA

HEXAGON HEAD FLANGE BOLTS

SECHSKANTSCHRAUBE MIT FLANSCH

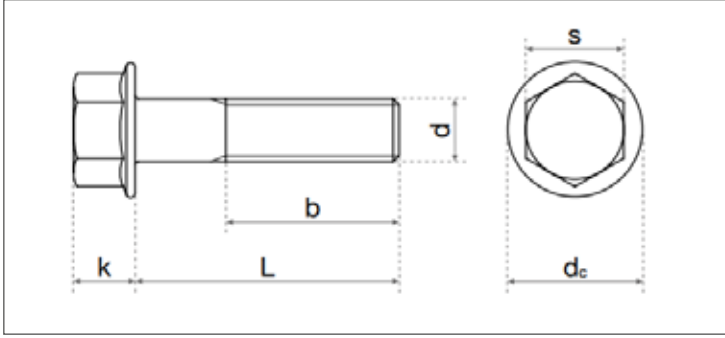

ISO	UNI	DIN
1665	-	6921 A2/A4
Mekanik Özellikler - Toleranslar Mechanical Properties - Tolerances Mechanische Eigenschaften - Toleranzen		ISO 3506-1 ISO 4759-1

TEKNİK BİLGİLER		TECHNICAL INFORMATIONS			TECHNISCHE INFORMATION	
d		M5	M6	M8	M10	M12
p		0,8	1	1,25	1,5	1,75
s	max	8	10	13	15	16
	min	7,78	9,78	12,73	14,73	15,73
e	max	8,71	10,95	14,26	16,5	17,62
k	max	5,4	6,6	8,1	9,2	11,5
dc	max	11,8	14,2	18	22,3	26,6
	≤ 125	16	18	22	26	30
b	I > 125 (125 < I ≤ 200)			28	32	36
	I > 200					

I	min	max	M5	M6	M8	M10	M12
10	9,71	10,29	3,70	6,18			
12	11,65	12,35	3,94	6,52	12,70		
14	15,65	16,35	4,19	6,87	13,30		
16	15,65	16,35	4,44	7,21	14,00	24,70	
18	17,65	18,35	4,69	7,56	14,60		
20	19,58	20,42	4,95	7,90	15,20	27,70	43,20
22	21,58	22,42	5,20	8,25	15,80	25,70	45,20
25	24,58	25,42	6,40	8,95	16,70	30,00	46,60
30	29,58	30,42	7,20	11,00	21,70	31,60	50,00
35	34,50	35,50		12,00	23,70	36,00	53,40
40	39,50	40,50		13,30	25,70	42,40	63,00
45	44,50	45,50		14,50	27,50	45,40	72,00
50	49,50	50,50		15,50	29,50	48,50	76,00

INOX BOMBE BAŞLI İMBUS CIVATA

BUTTON HEAD SOCHET SCREWS

LINSENKOPFSCHRAUBE MIT INNENSECHSKANT

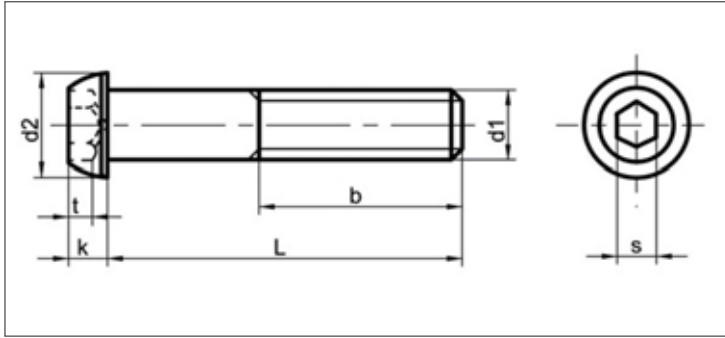

ISO	UNI	DIN
7380	7380	7380 A2/A4
Mekanik Özellikler - Toleranslar Mechanical Properties - Tolerances Mechanische Eigenschaften - Toleranzen		ISO 3506-1 ISO 4759-1

TEKNİK BİLGİLER		TECHNICAL INFORMATION				TECHNISCHE INFORMATION			
d		M3	M4	M5	M6	M8	M10	M12	
p		0,50	0,70	0,80	1,00	1,25	1,50	1,75	
dk	max	5,7	7,6	9,5	10,5	14	17,5	21	
	min	5,40	7,24	9,14	10,07	13,57	17,07	20,48	
k	max	1,65	2,2	2,75	3,3	4,4	5,5	6,6	
	min	1,40	1,95	2,50	3,00	4,10	5,20	6,24	
s	nominal	2	2,5	3	4	5	6	8	
	max	2,04	2,56	3,07	4,08	5,08	6,09	8,11	
	min	2,02	2,52	3,02	4,02	5,02	6,02	8,02	
t	min	1,04	1,3	1,56	2,08	2,6	3,2	4,16	

l	min	max	M3	M4	M5	M6	M8	M10	M12
6	5,76	6,24	0,50	0,88	1,65				
8	7,71	8,29	0,57	1,14	1,96	3,41			
10	9,71	10,29	0,67	1,34	2,27	3,72	7,43		
12	11,65	12,35	0,77	1,55	2,58	4,03	7,95		
14	13,65	14,35	0,88	1,75	2,89	4,34	8,46		
16	15,65	16,35	0,98	1,96	3,20	4,65	9,08	16,00	
18	17,65	18,35	1,08	2,17	3,51	5,01	9,81	17,20	
20	19,58	20,42	1,19	2,37	3,82	5,37	10,50	18,50	
25	24,58	25,42		2,89	4,54	6,40	12,90	21,70	30,50
30	29,58	30,42		3,41	5,26	7,54	14,50	22,70	33,50
35	34,50	35,50		3,92	5,99	8,57	16,20	26,30	37,70
40	39,50	40,50			6,71	9,60	18,10	29,40	41,30
45	44,50	45,50				10,60	19,90	32,50	46,50
50	49,50	50,50				11,70	21,80	35,60	51,60
55	54,40	55,60				12,70	23,60		
60	59,40	60,60				13,70	25,50	41,80	61,90

INOX YILDIZ SİLİNDİR BAŞLI SAÇ VİDASI

PHILLIPS PAN HEAD SELF TAPPING SCREWS

LINSENKOPF-BLECHSCHRAUBE KREUZ

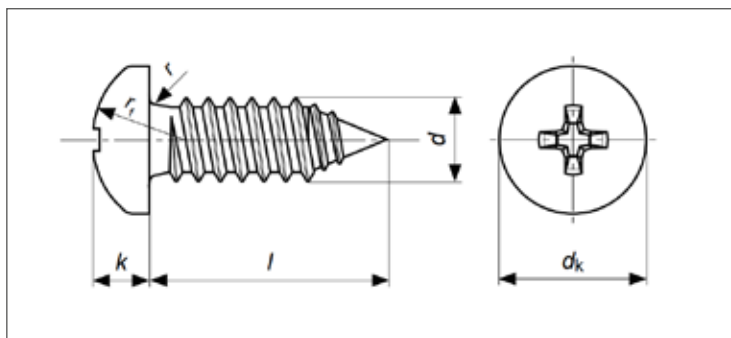

ISO	UNI	DIN
7049	6954	7981 A2/A4
Mekanik Özellikler - Toleranslar Mechanical Properties - Tolerances Mechanische Eigenschaften - Toleranzen		ISO 3506-4 ISO 4759-1

TEKNIK BİLGİLER		TECHNICAL INFORMATIONS								TECHNISCHE INFORMATION		
d		2,2	2,9	3,5	3,9	4,2	4,8	5,5	6,3			
dk	max	4,2	5,60	6,90	7,5	8,2	9,5	10,8	12,5			
	min	3,9	5,3	6,54	7,14	7,84	9,14	10,37	12,07			
k	max	1,8	2,20	2,6	2,8	3,05	3,55	3,95	4,55			
	min	1,55	1,95	2,35	2,55	2,75	3,25	3,65	4,25			
r	max	0,30	0,40	0,50	0,5	0,60	0,7	0,8	0,9			
rf	≈	3,40	4,40	5,40	5,8	6,2	7,20	8,20	9,50			
Nº	Phillips Recess No PH Drv N	1			2				3			
m	≈	2,6	3	4,2	4,4	4,8	5	6,5	7,1			
Soket Derinliği H Penetration Depth H	max	1,32	1,8	2,03	2,28	2,46	2,87	3,15	6,7			
	min	0,86	1,35	1,4	1,63	1,8	2,26	2,49	3,66			

l	Type C		Type F		2,2	2,9	3,5	3,9	4,2	4,8	5,5	6,3
	min	max	min	max								
4,5	3,7	5,3	3,7	4,5	0,21	0,41	0,66	0,88	1,05			
6,5	5,7	7,3	5,7	6,5	0,27	0,52	0,81	1,08	1,25	1,90		
9,5	8,7	10,3	8,7	9,5	0,34	0,65	1	1,30	1,50	2,26	3,29	4,01
13	12,2	13,8	12,2	13	0,40	0,76	1,15	1,50	1,72	2,57	3,70	4,56
16	15,2	16,6	15,2	16		0,87	1,3	1,69	1,93	2,88	4,11	5,11
19	18,2	19,8	18,2	19		0,99	1,46	1,89	2,16	3,18	4,5	5,67
22	21,2	22,8	20,7	22		1,1	1,61	2,08	2,36	3,49	4,89	6,22
25	24,2	25,8	23,7	25		1,37	1,97	2,54	2,88	4,21	5,82	7,52
32	30,7	33,3	30,7	32		1,48	2,28	2,93	3,26	4,83	6,62	8,63
38	36,7	39,3	36,7	38			2,64	3,39	3,75	5,55	7,5	9,92
45	43,7	46,3	43,7	45			2,9	3,72	4,1	6,06	8,16	10,85
50	48,7	51,3	48,7	50						7,34	10,77	14,54
70										8,63	13,38	18,24
80										9,91	15,99	21,94

INOX YILDIZ MERCİMEK BAŞLI SAÇ VİDASI

PHILLIPS COUNTERSUNK RAISED HEAD SELF TAPPING SCREWS

LINSENENK-BLECHSCHRAUBEN MIT KREUZSCHLITZ

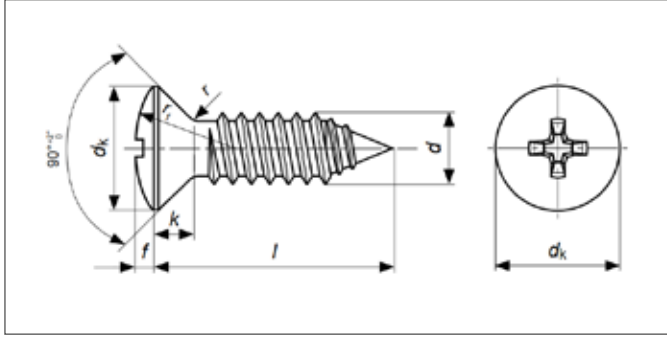

ISO	UNI	DIN
7051	6956	7983 A2/A4
Mekanik Özellikler - Toleranslar Mechanical Properties - Tolerances Mechanische Eigenschaften - Toleranzen		ISO 3506-4 ISO 4759-1

TEKNIK BİLGİLER		TECHNICAL INFORMATIONS								TECHNISCHE INFORMATION		
d		2,2	2,9	3,5	3,9	4,2	4,8	5,5	6,3			
dk	max	4,3	5,5	6,8	7,5	8,1	9,5	10,8	12,4			
f	≈	0,7	0,9	1,2	1,3	1,4	1,5	1,7	2			
k	≈	1,3	1,7	2,1	2,3	2,5	3	3,4	3,8			
r	max	0,8	1,1	1,4	1,5	1,6	1,9	2,1	2,4			
rf	≈	3,8	4,6	5,4	6	6,6	8,2	9,4	11,1			
N°	Phillips Recess No PH Drv No	1			2				3			
m	≈	2,8	3,4	4,6	4,7	4,9	5,4	7	7,4			
Soket Derinliği H Penetration Depth H	max	1,57	2,21	2,39	2,54	2,74	3,2	3,53	3,96			
	min	1,17	1,81	1,89	2,04	2,24	2,7	3,02	3,46			

l	min	max	2,2	2,9	3,5	3,9	4,2	4,8	5,5	6,3
6,5	5,70	7,30	0,14	0,29	8,40	0,48				
9,5	8,70	10,30	0,21	0,36	0,55	0,68	0,79	1,13		
13	12,20	13,80	0,28	0,49	0,74	0,90	1,05	1,49	2,17	2,60
16	15,20	16,60	0,34	0,60	0,89	1,10	1,26	1,80	2,56	3,15
19	18,20	19,80		0,71	1,05	1,29	1,48	2,10	2,95	3,71
22	21,20	22,80		0,82	1,20	1,49	1,69	2,41	3,35	4,26
25	24,20	25,80		0,93	1,36	1,68	1,91	2,72	3,75	4,82
32	30,70	33,30		1,19	1,90	2,37	2,41	3,44	4,68	6,11
38	36,70	39,30		1,38	2,21	2,53	2,84	4,06	5,48	7,22
45	43,70	46,30			2,38	3,07	3,35	4,78	6,42	8,51
50	48,70	51,30			2,64	3,40	3,71	5,29	7,09	9,44
60								6,32	8,42	11,29
70								7,34	9,76	13,14
80								8,37	11,09	14,98

INOX YILDIZ SİLİNDİR BAŞLI METRİK VİDA

CROSS RECESSED PAN HEAD SCREWS

LINSENKOPFSCHRAUBE MIT KREUZSCHLITZ

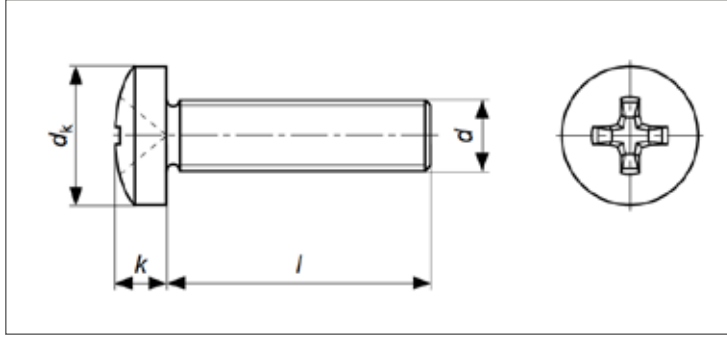

ISO	UNI	DIN
7045	7687	7985 A2/A4
Mekanik Özellikler - Toleranslar Mechanical Properties - Tolerances Mechanische Eigenschaften - Toleranzen		ISO 3506-1 ISO 4759-1

TEKNİK BİLGİLER		TECHNICAL INFORMATIONS					TECHNISCHE INFORMATION	
d		M2	M2,5	M3	M4	M5	M6	M8
dk	max	4	5	6	8	10	12	16
	min	3,7	4,7	5,7	7,64	9,64	11,57	15,57
k	nominal	1,6	2	2,4	3,1	3,8	4,6	6
	max	1,72	2,12	2,52	3,25	3,95	4,75	6,15
	min	1,48	1,88	2,28	2,95	3,65	4,45	5,85
Nº	Phillips Recess No PH Drv No	1			2		3	4
m	≈	2,5	2,7	3,1	4,6	5,3	6,8	9
Soket Derinliği H Penetration Depth H	max	1,4	1,6	2	2,54	3,27	3,53	4,68
	min	1,1	1,3	1,7	2,04	2,77	3,03	4,18

l	min	max	M2	M2,5	M3	M4	M5	M6	M8
4	3,75	4,25	0,20	0,38	0,56				
5	4,75	5,25	0,22	0,41	0,60	1,41			
6	5,75	6,25	0,24	0,44	0,65	1,50	2,38		
7					0,69	1,57	2,51		
8	7,7	8,3	0,28	0,50	0,74	1,73	2,99	4,48	
10	9,7	10,3	0,31	0,56	0,83	1,89	3,25	4,84	11,48
12	11,65	12,35	0,35	0,62	0,92	2,05	3,51	5,20	12,20
14	13,65	14,35	0,39	0,68	1,01	2,20	3,77	5,56	
16	15,65	16,35	0,43	0,74	1,10	2,36	4,03	5,92	13,53
18	17,65	18,35			1,18	2,52	4,29	6,29	
20	19,6	20,4	0,50	0,87	1,28	2,69	4,55	6,64	15,17
22	21,6	22,4			1,38	2,92	4,81	6,99	
25	24,6	25,4		1,02	1,51	3,31	5,16	7,54	16,81
30	29,6	30,4			1,73	3,71	5,85	8,45	18,45
35	34,5	35,5			1,96	4,11	6,60	9,35	20,09
40	39,5	40,5			2,18	4,51	7,50	10,25	21,13
45	44,5	45,5			2,41	4,91	8,20	11,17	22,80
50	49,5	50,5			2,63	5,31	8,90	12,10	24,40
55	54	56				5,71	9,70	12,92	26,00
60	59	61				6,11	10,47	13,84	27,70
70	69	71					11,90	15,56	31,00
80	79	81						17,31	34,00
90									37,00
100									40,00

INOX HAVŞA BAŞLI İMBUS CIVATA

HEXAGON SOCKET COUNTERSUNK HEAD CAP SCREWS

SENKSCRAUBEN MIT INNENSECHSKANT

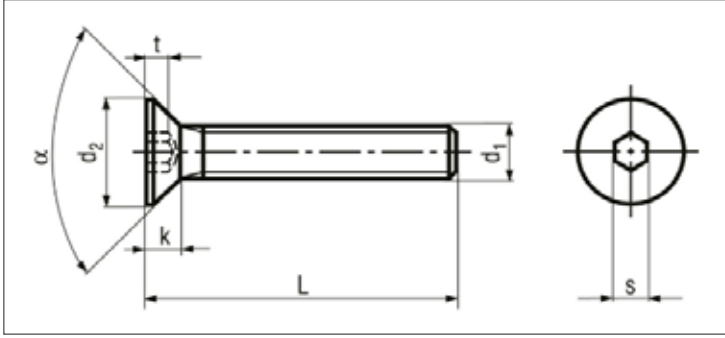

ISO	UNI	DIN
10642	5933	7991 A2/A4
Mekanik Özellikler - Toleranslar Mechanical Properties - Tolerances Mechanische Eigenschaften - Toleranzen		ISO 3506-1 ISO 4759-1

TEKNIK BİLGİLER	TECHNICAL INFORMATION	TECHNISCHE INFORMATION
-----------------	-----------------------	------------------------

		M3	M4	M5	M6	M8	M10	M12	M14	M16	M18	M20
d												
p		0,5	0,7	0,8	1	1,25	1,5	1,75	2	2	2,5	2,5
s	nominal	2	2,5	3	4	5	6	8	10	10	12	12
	min	2,02	2,52	3,02	4,02	5,02	6,02	8,02	10,02	10,02	12,03	12,03
	max	2,10	2,60	3,10	4,12	5,14	6,14	8,17	10,17	10,17	12,21	12,21
e	min	2,30	2,87	3,44	4,58	5,72	6,86	9,15	11,43	11,43	13,72	13,72
	max	6	8	10	12	16	20	24	27	30	33	36
dk	min	5,70	7,64	9,64	11,57	15,57	19,48	23,48	26,48	29,48	32,38	35,38
	max	1,7	2,3	2,8	3,3	4,4	5,5	6,5	7	7,5	8	8,5
k	min	1,2	1,8	2,3	2,5	3,5	4,4	4,6	4,8	5,3	5,5	5,9
	max	0,95	1,55	2,05	2,25	3,2	4,1	4,3	4,5	5	5,2	5,6
b	≤ 125	12	14	16	18	22	26	30	34	38	42	46
	I > 125 (125 < I ≤ 200)				24	28	32	36	40	44	48	52
	I > 200						45	49	53	57	61	65

l	min	max	M3	M4	M5	M6	M8	M10	M12	M14	M16	M18	M20
6	5,76	6,24	0,38	0,78	1,37								
8	7,71	8,29	0,48	0,93	1,62	2,38							
10	9,71	10,29	0,57	1,08	1,87	2,73	5,54						
12	11,65	12,35	0,66	1,24	2,13	3,09	6,17	10,22					
14	13,65	14,35	0,73	1,44	2,25	3,29	6,48	11,13					
16	15,65	16,35	0,84	1,55	2,62	3,81	7,44	12,25					
18	17,58	18,42	0,9	1,78	2,73	4,00	7,73	13,05					
20	19,58	20,42	1,01	1,86	3,13	4,51	8,70	14,27	21,45				
22	21,58	22,42	1,12	1,94	3,52	5,03							
25	24,58	25,42	1,37	2,26	3,75	5,40	10,32	16,80	25,10	32,99			
30	29,58	30,42	1,65	2,93	4,38	6,29	11,84	19,33	28,84	38,05	52,42		
35	34,50	35,50		3,44	5,50	7,19	13,46	21,86	32,49	43,10	59,10		92,50
40	39,50	40,50		3,95	6,27	8,94	14,98	24,39	36,13	47,97	65,88		103,22
45	44,50	45,50		4,45	6,43	9,11	16,70	26,62	38,35	52,93	71,55		111,32
50	49,50	50,50		4,96	7,83	11,13	20,14	30,46	43,52	57,99	79,34		124,48
55	54,40	55,60			8,40	12,26	22,77	32,38	45,64	62,95	85,01		132,57
60	59,40	60,60		5,97	9,18	13,37	25,10	36,13	54,65	67,91	92,80		144,72
65	64,40	65,60			9,96	14,47							
70	69,40	70,60			10,74	15,57	30,46	41,69	63,65	72,86	112,33		165,97
80	79,40	80,60			12,30	17,77	35,62	47,26	72,66	77,82	128,52		202,40
90	89,30	90,70				19,98	40,78	52,83	81,67	87,74	144,72		228,71
100	99,30	100,70				22,18	45,94	58,39	90,68	97,66	171,03		256,04
110	109,30	110,70					51,11	63,96	99,68				
120	119,30	120,70					56,27	69,52	108,69				

INOX DÜZ KAMA

PARALLEL KEYS

PASSFEDERN

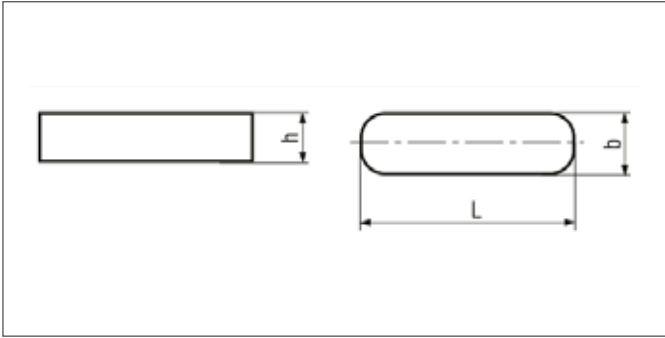

ISO	UNI	DIN
R773	6604/A	6885A A2/A4
Mekanik Özellikler - Toleranslar Mechanical Properties - Tolerances Mechanische Eigenschaften - Toleranzen		ISO 3506-3

TEKNIK BİLGİLER		TECHNICAL INFORMATIONS			TECHNISCHE INFORMATION	
bxh	4x4	5x5	6x6	8x7	10x8	12x8
l						
8	0,91					
10	1,17					
12	1,42	2,16	3,10			
14	1,67	2,57	3,62			
15	1,85	2,75	3,95	6,05		
16	1,92	2,96	4,21	6,45		
18	2,18	3,36	4,78	7,26		
20	2,43	3,75	5,26	8,14	11,45	13,84
22	2,68	4,16	5,93	9,02		
25	3,07	4,76	6,79	10,37	14,52	17,31
28	3,45	5,35	7,64	11,68		
30	3,69	5,73	8,11	12,59	17,78	21,02
32	3,96	6,14	8,78	13,51		
35	4,33	6,64	9,71	14,70	20,90	24,75
36	4,46	6,93	9,95	15,23		
40	4,97	7,73	11,07	17,05	24,04	28,50
45	5,61	8,72	12,48	19,27	27,27	32,34
50	6,23	9,71	13,90	21,50	30,41	36,19
55		10,70	15,34	23,70	33,64	40,01
56		10,92	15,62	24,13	34,26	40,74
60		11,70	16,74	25,97	36,86	43,91
65		12,67	18,26	28,13		47,80
70			19,67	30,41	43,16	50,07
75			21,07	32,58	46,25	53,66
80			22,48	34,86	49,44	57,23
90				39,31	55,81	64,38
100				43,68	62,19	71,54

INOX ALTİKÖŞE PUL BAŞLI MATKAP UÇLU VİDA

HEXAGON WASHER HEAD SELF DRILLING SCREW

SECHSKANT-SELBSTBOHRENDE SCHRAUBE MIT BUND

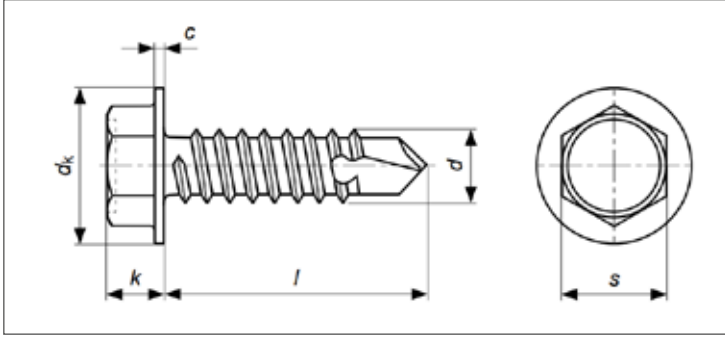

ISO	UNI	DIN
15480	8117	7504K A2/A4
Mekanik Özellikler - Toleranslar Mechanical Properties - Tolerances Mechanische Eigenschaften - Toleranzen		ISO 3506-4 ISO 4759-1

TEKNİK BİLGİLER		TECHNICAL INFORMATIONS				TECHNISCHE INFORMATION		
d		3,5	3,9	4,2	4,8	5,5	6,3	
K	max	3,4	3,45	4,1	4,3	5,4	5,9	
	min	3	3,2	3,6	3,8	4,8	5,3	
dk	max	8,3	8,3	8,8	10,5	11	13,5	
	min	7,6	7,6	8,1	9,8	10	12,2	
c	min	0,6	0,6	0,8	0,9	1	1	
Nº	NST Recess No MG Drv No	5,5	5,5	7	8	8	10	
s	max	5,5	5,5	7	8	8	10	
	min	5,32	5,32	6,78	7,78	7,78	9,78	
Plaka/Levha Kalınlığı Steel Thickness	max	2,25	2,40	3	4,4	5,25	6	
	min	0,7	1	1,75	1,75	1,75	2	

l	min	max	3,5	3,9	4,2	4,8	5,5	6,3
9,5	8,75	10,25	1,20					
13	12,10	13,90	1,35	1,45	1,70	2,60		
16	15,10	16,90	1,45	1,60	1,85	2,90	3,60	5,80
19	18,00	20,00	1,70	1,88	2,10	3,20	4,00	6,40
22	21,00	23,00		2,07	2,30	3,60	4,50	7,00
25	24,00	26,00		2,29	2,50	3,90	4,90	7,60
32	30,75	33,25		2,70	3,00	4,20	5,90	9,00
38	36,75	39,25			3,50	4,60	6,80	10,10
45	43,75	46,25				5,00	7,75	11,50
50	48,75	51,25				5,30	8,50	12,50
60	58,80	61,20					10,00	13,70
70	68,80	71,20						14,90
80	78,80	81,20						16,30
90	88,80	91,20						17,70
100	98,80	101,20						19,10
110								20,90
120								22,70
130								24,20
140								25,80
150								27,40
160								28,90
170								30,40
180								31,90
190								33,40
200								34,90

INOX YILDIZ SİLİNDİR BAŞLI MATKAP UÇLU VİDA

CROSS RECESSED PAN HEAD SELF DRILLING SCREW

SELBSTBOHRENDE SCHRAUBE MIT LINSENKOPF

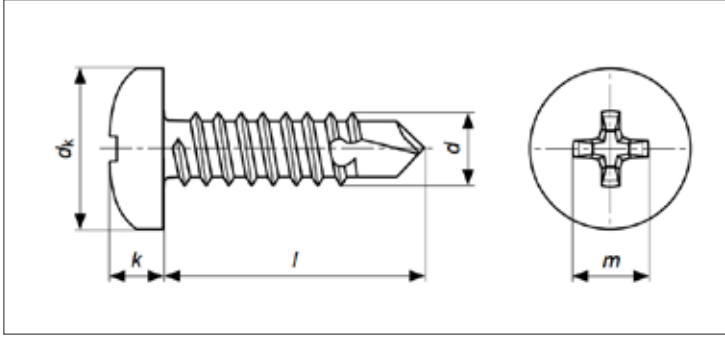

ISO	UNI	DIN
15481	8118	7504N A2/A4
Mekanik Özellikler - Toleranslar Mechanical Properties - Tolerances Mechanische Eigenschaften - Toleranzen		ISO 3506-4 ISO 4759-1

TEKNİK BİLGİLER		TECHNICAL INFORMATIONS					TECHNISCHE INFORMATION		
d		2,9	3,5	3,9	4,2	4,8	5,5	6,3	
k	max	2,4	2,6	3,1	3,1	3,7	4	4,6	
	min	2,15	2,35	2,8	2,8	3,4	3,7	4,3	
dk	max	5,6	7	7,5	8	9,5	11	12	
	min	5,3	6,64	7,14	7,64	9,14	10,57	11,57	
N°	Phillips Recess No PH Drv No	1	2				3		
m	≈	3	3,9	4,2	4,4	4,9	6,4	6,9	
Soket Derinliği H Penetration Depth H	max	1,8	1,9	2,4	2,4	2,9	3,1	3,6	
	min	1,4	1,4	1,9	1,9	2,4	2,6	3,1	
Plaka/Levha Kalınlığı Steel Thickness	max	1,9	2,25	2,65	3	4,4	5,25	6	
	min	0,7	0,7	1	1,75	1,75	1,75	2	

l	min	max	2,9	3,5	3,9	4,2	4,8	5,5	6,3
9,5	8,75	10,25	0,54	1,05					
13	12,10	13,90	0,66	1,20	1,30	1,50	2,20		
16	15,10	16,90	0,77	1,40	1,50	1,80	2,50		
19	18,00	20,00	0,88	1,50	1,70	1,95	2,80	3,80	5,40
22	21,00	23,00		1,70	1,85	2,20	3,10	4,20	5,95
25	24,00	26,00		2,00	2,10	2,40	3,40	4,50	6,50
32	30,75	33,25					4,10	5,50	7,80
38	36,75	39,25					4,70	6,20	8,90
45	43,75	46,25					5,40	7,10	10,00
50	48,75	51,25					5,90	7,80	11,00
60	58,80	61,20					6,90		12,00
70	68,80	71,20							13,30
80	78,80	81,20							14,90
90	88,80	91,20							16,50
100	98,80	101,20							18,10

INOX YILDIZ HAVŞA BAŞLI MATKAP UÇLU VİDA

CROSS RECESSED COUNTERSUNK HEAD SCREW

SENKOPFSCHRAUBE MIT KREUZ

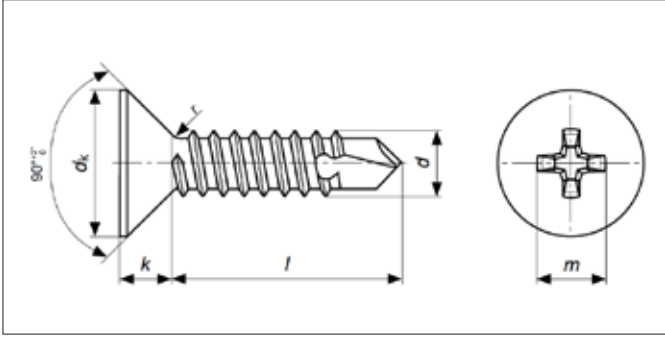

ISO	UNI	DIN
15482	8119	7504P A2/A4
<i>Mekanik Özellikler - Toleranslar</i> <i>Mechanical Properties - Tolerances</i> <i>Mechanische Eigenschaften - Toleranzen</i>		ISO 3506-4 ISO 4759-1

TEKNIK BİLGİLER		TECHNICAL INFORMATION							TECHNISCHE INFORMATION	
d		2,9	3,5	3,9	4,2	4,8	5,5	6,3		
k	max	2,4	2,6	3,1	3,1	3,7	4	4,6		
	min	2,15	2,35	2,8	2,8	3,4	3,7	4,3		
dk	max	5,6	7	7,5	8	9,5	11	12		
	min	5,3	6,64	7,14	7,64	9,14	10,57	11,57		
Nº	Phillips Recess No PH Drv No	1	2					3		
m	≈	3	3,9	4,2	4,4	4,9	6,4	6,9		
Soket Derinliği H Penetration Depth H	max	1,8	2	2,4	2	2,9	3,1	3,6		
	min	1,4	1,4	1,9	1,9	2,4	2,6	3,1		
Plaka/Levha Kalınlığı Steel Thickness	max	1,9	2,25	2,65	3	4,40	5,25	6		
	min	0,7	0,7	1	1,75	1,75	1,75	2		

l	min	max	2,9	3,5	3,9	4,2	4,8	5,5	6,3
13	12,10	13,90	0,48	0,72	0,90	1,10	1,50		
16	15,10	16,90	0,59	0,88	1,10	1,30	1,60	2,50	
19	18,00	20,00	0,70	1,10	1,30	1,50	1,80	2,80	3,60
22	21,00	23,00	0,90	1,20	1,46	1,70	2,40	3,30	4,15
25	24,00	26,00	1,00	1,40	1,65	1,90	2,70	3,70	4,70
32	30,75	33,25		1,80	1,90	2,50	3,40	4,70	5,95
38	36,75	39,25		2,00	2,15	3,00	4,00	5,40	7,10
45	43,75	46,25				3,60	4,70	6,30	8,40
50	48,75	51,25					5,20	7,00	9,30
60	58,80	61,20					5,70		10,10
70	68,80	71,20					6,30		11,80
80	78,80	81,20					6,90		13,60
90	88,80	91,20							15,30
100	98,80	101,20							17,10

